**NAVAIR 01-1B-50
AIR FORCE TO 1-1B-50
COAST GUARD TO 1-1B-50
ARMY TM 55-1500-342-23**

JOINT SERVICE TECHNICAL MANUAL

ORGANIZATIONAL, INTERMEDIATE, AND DEPOT
MAINTENANCE

AIRCRAFT WEIGHT AND BALANCE

Includes IRAC 1.

SUPERSEDURE NOTICE. This manual supersedes NAVAIR 01-1B-50 dated 01 August 2015, USAF TO 1-1B-50 dated 01 August 2015, USCG TO 1-1B-50 dated 01 August 2015, and ARMY TM 55-1500-342-23 dated 01 August 2015. Destroy previously issued versions of these manuals to prevent disclosure of contents or reconstruction of the documents.

DISTRIBUTION STATEMENT A. Approved for public release; distribution is unlimited.

DESTRUCTION NOTICE. For unclassified, limited documents, destroy by any method that will prevent disclosure of contents or reconstruction of the document.

PUBLISHED BY DIRECTION OF COMMANDER, NAVAL AIR SYSTEMS COMMAND

LIST OF EFFECTIVE PAGES

Dates of issue for original and changed pages are:

Original 0.....01 August 2019
 (Includes IRAC 1)

Insert latest changed pages; dispose of superseded pages in accordance with applicable regulations.

NOTE: On a changed page, the portion of the text affected by the latest change is indicated by a vertical line, or other change symbol in the outer margin of the page. Change in illustrations are indicated by miniature pointing hands. Changes to wiring diagrams are indicated by shaded areas.

Total number of pages in this manual is 100, consisting of the following:

Page No.	*Change No.	Page No.	*Change No.	Page No.	*Change No.
Title	0	3-1 - 3-4	0	8-28 Blank	0
A	0	4-1 - 4-14	0	8-29 - 8-32	0
i-iii	0	5-1 - 5-10	0	A-1 - A-7	0
iv Blank	0	6-1 - 6-3	0	A-8 Blank	0
TPDR-1	0	6-4 Blank	0	B-1 - B-2	0
TPDR-2 Blank	0	7-1 - 7-9	0	C-1	0
1-1 - 1-2	0	7-10 Blank	0	C-2 Blank	0
2-1 - 2-4	0	8-1 - 8-27	0		

*Zero in this column indicates an original page.

TABLE OF CONTENTS

Chapter	Page	Chapter	Page
LIST OF ILLUSTRATIONS	iii		
LIST OF TABLES	iii		
LIST OF TECHNICAL PUBLICATIONS			
DEFICIENCY REPORTS (TPDR)			
INCORPORATED	TPDR-1		
1 INTRODUCTION			
1.1 Purpose	1-1		
1.2 Scope	1-1		
1.3 Terminology	1-1		
1.4 Reasons for Weight and Balance			
Control	1-1		
1.5 Comments	1-2		
2 AIRCRAFT WEIGHT AND BALANCE PRINCIPLES			
2.1 Aircraft Weight Principles	2-1		
2.2 Aircraft Balance Principles	2-2		
2.3 Calculating Aircraft Center of Gravity	2-2		
2.4 Fuselage Station	2-3		
2.5 Percent Mean Aerodynamic Chord			
(% MAC)	2-4		
2.6 Loading / Unloading	2-4		
2.7 Ballast.....	2-4		
3 WEIGHT AND BALANCE SYSTEM			
3.1 General.....	3-1		
3.2 Manufacturer Responsibilities	3-1		
3.3 Commercial Maintenance			
Responsibilities	3-1		
3.4 Depot / Intermediate Level			
Maintenance Responsibilities.....	3-1		
3.5 Aircraft Custodian/Technician/Type			
Commander Responsibilities.....	3-1		
3.6 Aircraft Weight and Balance			
Classifications	3-1		
3.7 Weight and Balance Handbooks	3-1		
3.8 Weight and Balance Flight			
Clearance	3-3		
3.9 Aircraft Weighing Requirements.....	3-4		
4 INSTRUCTIONS FOR THE USE OF WEIGHT AND BALANCE CHARTS AND FORMS			
4.1 Form Retention and Disposition	4-1		
4.2 DD Form 365: Record of Weight and			
Balance Personnel or Electronic			
Equivalent.....	4-1		
		4.3 DD Form 365-1: Chart A -	
		Basic Weight Checklist Record or	
		Electronic Equivalent.....	4-1
		4.4 DD Form 365-2: Form B -	
		Aircraft Weighing Record or	
		Electronic Equivalent.....	4-3
		4.5 DD Form 365-3: Chart C -	
		Basic Weight and Balance Record or	
		Electronic Equivalent.....	4-5
		4.6 Chart E - Aircraft Loading Manual /	
		Weighing Instructions	4-6
		4.7 DD Form 365-4: Weight and Balance	
		Clearance Form F or	
		Electronic Equivalent.....	4-6
		5 WEIGHING AIRCRAFT	
		5.1 General.....	5-1
		5.2 Weighing Equipment	5-1
		5.3 Weighing Accessories	5-3
		5.4 Weighing Procedures	5-4
		5.5 Verification of Weighing Results.....	5-9
		6 WEIGHT AND BALANCE TOOLS	
		6.1 Automated Weight and Balance	
		System (AWBS).....	6-1
		6.2 Other Weight and Balance Tools	6-1
		7 CENTER OF GRAVITY LOADING CALCULATIONS	
		7.1 General.....	7-1
		7.2 Principles of Moments	7-1
		7.3 Effects of Moment on Aircraft CG	7-2
		7.4 Determination of Balance Condition	
		(Location of Aircraft Center	
		of Gravity)	7-2
		7.5 Effects of Unbalanced Loading	7-3
		7.6 Determining Center of Gravity for a	
		Group of Items.....	7-3
		7.7 Center of Gravity Limits.....	7-3
		7.8 Expressing Center of Gravity	7-4
		7.9 Lateral CG and Vertical CG	7-4
		7.10 Most Forward and Most Aft	
		CG Calculations	7-4
		7.11 Sample	7-8
		7.12 Chart E Loading Data	7-9

TABLE OF CONTENTS (CONT.)

Chapter	Page	Chapter	Page
8 SERVICE SPECIFIC REQUIREMENTS			
8.1 US Army Requirements	8-1	8.3.3 Responsibilities	8-23
8.1.1 Related References	8-1	8.3.4 Personnel Qualification Requirements	8-24
8.1.2 Weight and Balance Control	8-1	8.3.5 Forms / Records Disposition	8-25
8.1.3 Responsibilities	8-2	8.3.6 Aircraft Classifications	8-25
8.1.4 Personnel Qualification Requirements	8-2	8.3.7 Form F	8-25
8.1.5 Forms and Records Disposition	8-2	8.3.8 Aircraft Weighing	8-27
8.1.6 Aircraft Classifications	8-3	8.3.9 Transfer / Acceptance Inventory	8-27
8.1.7 Form F	8-3	8.3.10 Scales	8-27
8.1.8 Aircraft Weighings	8-4	8.3.11 Unmanned Aerial Vehicles (UAVs)	8-27
8.1.9 Transfer and Acceptance of Aircraft	8-6	8.3.12 Weight and Balance Guidance for Aircraft Modifications	8-27
8.1.10 Scales	8-6	8.3.13 Contact Information	8-27
8.1.11 Unmanned Aircraft Systems (UAS)	8-6	8.3.14 Corrections to This Manual	8-27
8.1.12 Weight and Balance Guidance for Aircraft Modifications	8-6	8.3.15 Distribution of AWBS / AFFs	8-27
8.1.13 Contact Information	8-8		
8.1.14 Corrections to This Manual	8-8	8.4 US Coast Guard Requirements	8-29
8.1.15 Weight and Balance Software	8-8	8.4.1 Related References	8-29
8.1.16 Distribution of AWBS	8-8	8.4.2 Weight and Balance Control	8-29
		8.4.3 Responsibilities	8-29
8.2 US Navy / US Marine Corps Requirements	8-9	8.4.4 Personnel Qualification Requirements	8-30
8.2.1 Related References	8-9	8.4.5 Forms / Records Disposition	8-30
8.2.2 Weight and Balance Control	8-9	8.4.6 Aircraft Classifications	8-30
8.2.3 Responsibilities	8-10	8.4.7 Form F	8-30
8.2.4 Personnel Qualification Requirements	8-12	8.4.8 Aircraft Weighings	8-30
8.2.5 Retention and Disposition of Records / Charts / Forms	8-14	8.4.9 Transfer / Acceptance Inventory	8-31
8.2.6 Aircraft Classifications	8-14	8.4.10 Scales	8-31
8.2.7 Form F	8-15	8.4.11 Unmanned Aerial Vehicles (UAVs)	8-31
8.2.8 Aircraft Weighings	8-17	8.4.12 Weight and Balance Guidance for Aircraft Modifications	8-31
8.2.9 Transfer / Acceptance Inventory	8-18	8.4.13 Contact Information	8-32
8.2.10 Scales	8-18	8.4.14 Corrections to This Manual	8-32
8.2.11 Unmanned Aerial Vehicles / Systems (UAV / UAS)	8-19	8.4.15 Distribution of AWBS	8-32
8.2.12 Weight and Balance Guidance for Aircraft Modifications	8-19		
8.2.13 Contact Information	8-19	APPENDIX A. TERMINOLOGY AND DEFINITIONS	A-1
8.2.14 Corrections to This Manual	8-19		
8.2.15 AWBS Requirements	8-20	APPENDIX B. ACRONYMS	B-1
8.3 US Air Force Requirements	8-21	APPENDIX C. SCALE CORRECTIONS BLOCK TABLE FACTORS	C-1
8.3.1 Related References	8-21		
8.3.2 Weight and Balance Control	8-21		

LIST OF ILLUSTRATIONS

Figure	Title	Page	Figure	Title	Page
2-1.	Weight Terminology	2-1	7-6.	Example: Determine Required CG of Known Ballast Weight to Achieve Desired Effect on Aircraft CG	7-7
2-2.	Calculating Aircraft CG	2-2	7-7.	Example: Determine Required Ballast Weight at a Known CG to Achieve Desired Effect on Aircraft CG	7-8
2-3.	Balance Arm Fuselage Station	2-3	8-1.	Chart A Aircraft Modification Example.....	8-7
2-4.	Percent MAC Example	2-4	8-2.	Chart C Aircraft Modification Example	8-7
5-1.	Typical Platform Scale Assembly.....	5-1	8-3.	Form F Aircraft Modification Example.....	8-7
5-2.	Electronic Weighing Kit (Typical)	5-2	B-1.	Sample DD Form 365 Record of Weight and Balance Personnel.....	B-2
5-3.	Load Cell and Jack	5-2	B-2.	Sample DD Form 365-1 Chart A - Basic Weight Checklist Record	B-3
5-4.	Reading a Hydrometer.....	5-3	B-3.	Sample DD Form 365-2 Form B - Aircraft Weighing Record	B-4
5-5.	Accessory Weighing Kit	5-4	B-4.	Sample DD Form 365-3 Chart C - Basic Weight and Balance Record.....	B-6
5-6.	Estimation of "As Weighed" Condition	5-6	B-5.	Sample DD Form 365-4 Weight and Balance Clearance Form F - Transport.....	B-7
5-7.	Leveling Lugs Inside the Aircraft.....	5-7	B-6.	Sample DD Form 365-4 Weight and Balance Clearance Form F - Tactical	B-8
5-8.	Leveling Lugs Outside the Aircraft	5-7			
5-9.	Plumb Bob	5-7			
6-1.	Load Adjuster	6-3			
7-1.	Asymmetric Configurations.....	7-1			
7-2.	Aircraft Balance Point	7-2			
7-3.	Calculating Aircraft Center of Gravity.....	7-3			
7-4.	Example: Shift Unknown Weight a Known Distance To Achieve Desired Effect On Aircraft CG	7-6			
7-5.	Example: Shift Known Weight an Unknown Distance To Achieve Desired Effect On Aircraft CG	7-6			

LIST OF TABLES

Table	Title	Page	Table	Title	Page
3-1.	Major Modification or Repair Guideline.....	3-4	5-1.	Weighing Tolerances.....	5-10
3-2.	USAF Major Modifications or Repairs Guidelines.....	3-5	8-1.	Qualification Requirements.....	8-13
4-1.	Minimum Weight Threshold Guideline for Chart A Items.....	4-1	8-2.	USN / USMC Aircraft Classification Table.....	8-15
			8-3.	Minimum and Maximum Load vs. Scale Capacity	8-19
			8-4.	Minimum Load and Display Resolution	8-19

THIS PAGE LEFT INTENTIONALLY BLANK

LIST OF TECHNICAL PUBLICATIONS DEFICIENCY REPORTS INCORPORATED

Report Control Number (RCN)	Location	Report Control Number (RCN)	Location
N66051-16-0001.....	Para 3.8.6	N66051-16-0016.....	Para 8.2.15e
N66051-16-0002.....	Para 8.2.7a(3)	N66051-16-0017.....	Para 2.3
N66051-16-0003.....	Page 8-15	N66051-16-0018.....	Para 8.2.1e
N66051-16-0004.....	Para 8.2.9d	N66051-17-0019.....	Pg A-3
N66051-16-0005.....	Para 8.2.15	N66051-17-0020.....	Pg A-5
N66051-16-0006.....	Para 8.2.15f	N66051-17-0022.....	Para 8.2.12a
N66051-16-0007.....	Para 8.2.1a	N66051-17-0023	Para 8.2.3e(3)
N66051-16-0009.....	Para 8.2.2.c(3)(a)	N66051-17-0024.....	Para 8.2.2.c(3), 8.2.3.a, 8.2.7.b
N66051-16-0010.....	Table 8-1	N66051-17-0025.....	Para 8.2.3d(2)
N66051-16-0011	Para 4.7.1	N00421-19-0212.....	Section 8.1
N66051-16-0012.....	Para 8.2.15a	N00421-19-0226.....	Section 8.2
N66051-16-0014.....	Para 8.2.7d(2)	N00421-19-0227.....	Section 8.3
N66051-16-0015.....	Para 4.7.1		

THIS PAGE LEFT INTENTIONALLY BLANK

CHAPTER 1 INTRODUCTION

1.1 PURPOSE. This manual outlines and defines the requirements, procedures, and responsibilities for weight and balance control of military aircraft. This manual also provides information and instructions for maintaining the charts and forms (DD Form 365 series or electronic equivalent) that provide the means for maintaining continuous record and control of aircraft weight and balance. Information and explanation of principles, terms, and definitions are presented to provide weight and balance personnel with a general information manual pertinent to their particular function.

1.2 SCOPE. The use of this manual is mandatory for all units and organizations that either operate or maintain United States military aircraft, including fixed-wing and rotary-wing aircraft and select unmanned air vehicles. Each service's Engineering Organization for weight and balance may approve alternate methods of compliance with this technical manual. See Chapter 8 - Service Specific Requirements for additional information concerning select unmanned air vehicles. Sufficient explanation of principles, definitions, procedures and data are given to provide weight and balance personnel with a general information manual pertinent to their particular function. Also included is a complete description of related equipment and instructions for its use and operation. The general requirements and procedures of this manual are applicable to weight and balance control of all military aircraft. Additional requirements, procedures, and/or instructions for specific aircraft weight and balance control are specified in the aircraft specific manuals. See Chapter 8 - Service Specific Requirements for additional reference documents.

1.3 TERMINOLOGY.

1.3.1 Usage of the words "shall", "should", and "may" is in accordance with the following:

1.3.2 The word "shall," is used to indicate the requirements, procedures, and/or responsibilities are mandatory.

1.3.3 The word "should" is used to indicate a non-mandatory but highly recommended method of accomplishment.

1.3.4 The word "may" is used to indicate an acceptable or suggested means of accomplishment.

1.3.5 Weight and balance terminology and definitions are found in Appendix A. Acronyms are found in Appendix B.

1.3.6 Warnings, Cautions, and Notes Defined. Warnings, cautions, and notes are used to emphasize important and critical instructions and are used for the following conditions:

1.3.6.1 WARNING: An essential operating or maintenance procedure, practice, condition, statement, etc., which, if not strictly observed, could result in injury to, or death of, personnel or long term health hazards.

1.3.6.2 CAUTION: An essential operating or maintenance procedure, practice, condition, statement, etc., which, if not strictly observed, could result in damage to or destruction of, equipment or loss of mission effectiveness.

1.3.6.3 NOTE: An essential operating or maintenance procedure or condition that must be emphasized.

1.4 REASONS FOR WEIGHT AND BALANCE CONTROL. Since flight characteristics of aircraft are directly dependent upon conditions of weight and balance, using the principles and following the instructions contained in this manual can prevent dangerous flight conditions and potential associated mishaps. Gross Weight and center of gravity (CG) have a bearing on performance, stability, and control of the aircraft. For example, cargo placed too far aft in an already critically loaded aircraft could move the center of gravity out of the permissible balance limits. This could cause the pilot to lose control of the aircraft. Hazardous flight conditions and accidents resulting from these conditions can be prevented by adherence to the principles of weight and balance set forth in this manual. An aircraft whose weight is greater than its allowable maximum Gross Weight, or whose CG is located outside its prescribed CG limits, may experience one or more of the following unsatisfactory flight characteristics, performance degradations or payload reduction:

- a. Longitudinal instability.
- b. Lateral instability.
- c. Increase in takeoff distance.

- d. Increase in required power setting or torque.
- e. Increase in takeoff or landing speed.
- f. Increase in landing ground run.
- g. Increase in control forces.
- h. Increase in stall speeds.
- i. Decrease in range.
- j. Decrease in allowable payload.
- k. Decrease in rate of climb.
- l. Decrease in service ceiling.
- m. Decrease in structural safety factors.
- n. Decreased hover performance.
- o. Decreased cruising speed.
- p. Decreased maneuverability.

1.5 **COMMENTS.** See Chapter 8 - Service Specific Requirements for Points of Contact for each service.

**CHAPTER 2
 AIRCRAFT WEIGHT AND BALANCE PRINCIPLES**

2.1 AIRCRAFT WEIGHT PRINCIPLES. One of the basic elements of aircraft design is weight. The weight of an aircraft is used in determining such design criteria as engine requirements, wing area, landing gear requirements, and payload capacity. Any weight changes, whether in manufacturing, modification, or maintenance, can have distinct effects on aircraft performance and/or payload capability.

2.1.2 Weight Limits. All aircraft are designed with a number of weight limits. These limits are determined by a combination of performance, control, and structural restrictions. Exceeding these limits can result in loss of aircraft and is expressly forbidden.

2.1.3 Aircraft Weight. The weight of an aircraft is determined through a combination of actual weighing, accurate record keeping, and proper use of the aircraft specific manuals, charts, forms, and loading manuals.

2.1.1 Weight Terminology. Figure 2-1 illustrates the definition of, and relationships between, aircraft weight terminology. For related definitions, see Appendix A.

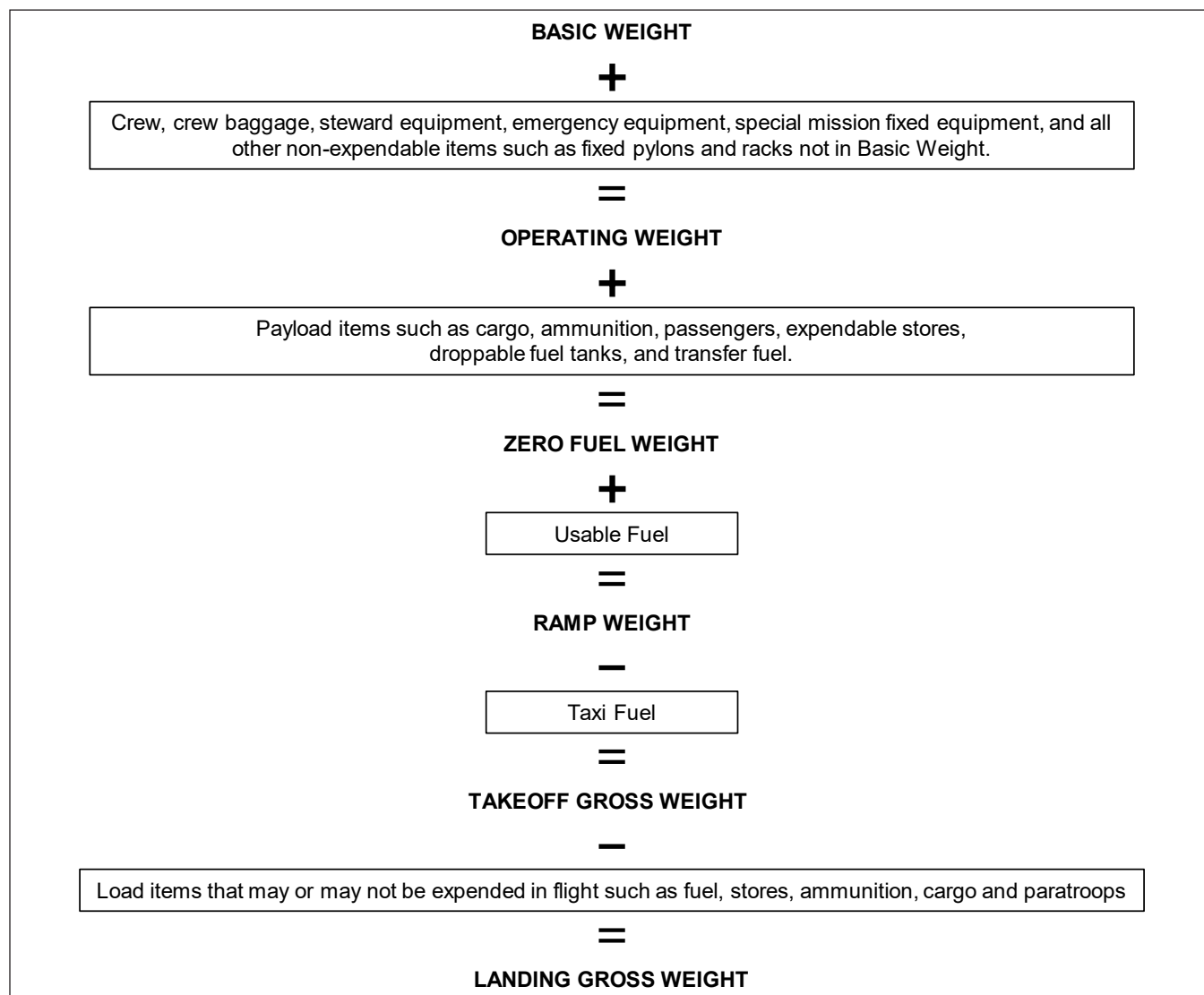

Figure 2-1. Weight Terminology

2.1.4 Floor Loading. Floor loading is the weight, in pounds, of a load divided by the area of floor on which the load rests. These limits shall never be exceeded.

2.1.4.1 For example, the floor loading for a 100-pound container is determined as follows:

$$\begin{aligned} \text{Base of container} &= 20 \text{ inches} \times 20 \text{ inches} = 400 \text{ square inches} \\ \text{Floor loading} &= \frac{100 \text{ pounds}}{400 \text{ square inches}} = 0.25 \text{ pounds per square inch} \end{aligned}$$

or:
 0.25 pounds per square inch x 144 square inches per square foot
 = 36 pounds per square foot

Floor loading limits or a plan view of the cargo floor showing variations in floor strength and weight concentration limitations for various compartments are specified in the applicable operator's manual.

NOTE

1 square foot = 144 square inches.

2.2 AIRCRAFT BALANCE PRINCIPLES. An aircraft is said to be in balance, or balanced, when all weight items in, on, or of the aircraft are distributed so that the

Center of Gravity (CG) of the aircraft is within allowable CG limits. These limits are defined by the most forward and aft permissible CG locations and are called the forward and aft CG limits, respectively. To determine if an aircraft is balanced, the aircraft CG shall be calculated and compared to the forward and aft CG limits for that particular configuration and Gross Weight. This can be calculated or not only longitudinal but the lateral and vertical conditions as well, although few aircraft track lateral or vertical CG. Refer to aircraft specific manuals in these cases.

2.2.1 Terminology. The terms balance, arm, balance arm, moment, simplified moment, load adjuster index, and Center of Gravity are fundamental to understanding aircraft balance and control. These, and other terms used in this Chapter, are defined in Appendix A.

2.3 CALCULATING AIRCRAFT CENTER OF GRAVITY

The CG of a loaded aircraft can be calculated when the weights and arms and/or moments of the items which make up the aircraft Gross Weight are known (see Figure 2-2). This can be done by using moments. The relationship between weight, arm and moment is as follows:

$$\text{WEIGHT} \times \text{ARM} = \text{MOMENT}$$

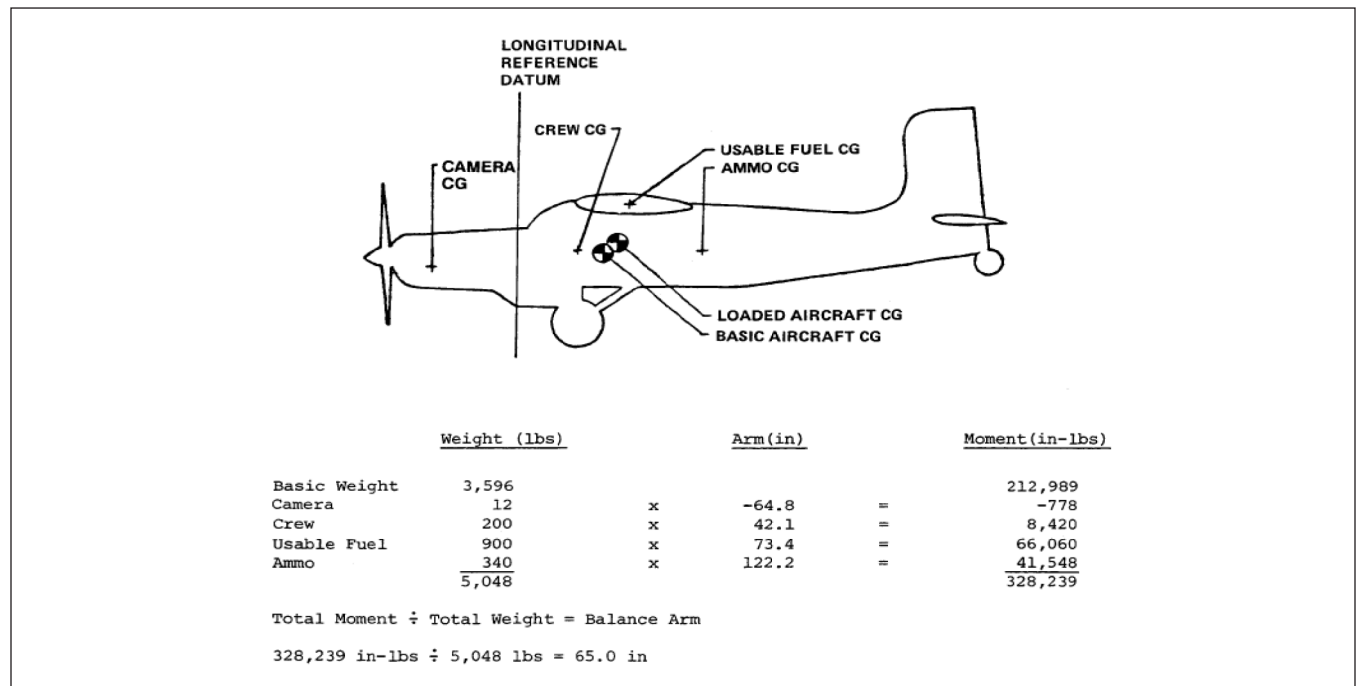

Figure 2-2. Calculating Aircraft CG

2.3.1 It is important to note that arms may not be added or subtracted when calculating CG. CG is calculated by taking the summation of total moments divided by the summation of total weights. Weights can be added or subtracted and moments can be added or subtracted but arms cannot be added or subtracted.

2.4 FUSELAGE STATION. Fuselage Station (FS) is frequently synonymous to the balance arm scale. However, if the aircraft fuselage is shortened or lengthened, the original fuselage sections usually retain their old FS designations but will have different balance

arms. This alters the FS–balance arm relationship (see Figure 2-3). The balance arm is what is used in the moment calculation formula. A fuselage plug can result in items being located ahead of the reference datum, leading to negative balance arms, as in Figure 2-3.

2.4.1 Balance calculations shall be made using balance arms; not FS locations. Use only balance arms. For those aircraft whose fuselage station differs from its balance arm, the aircraft-specific loading manual will provide a conversion table and further details.

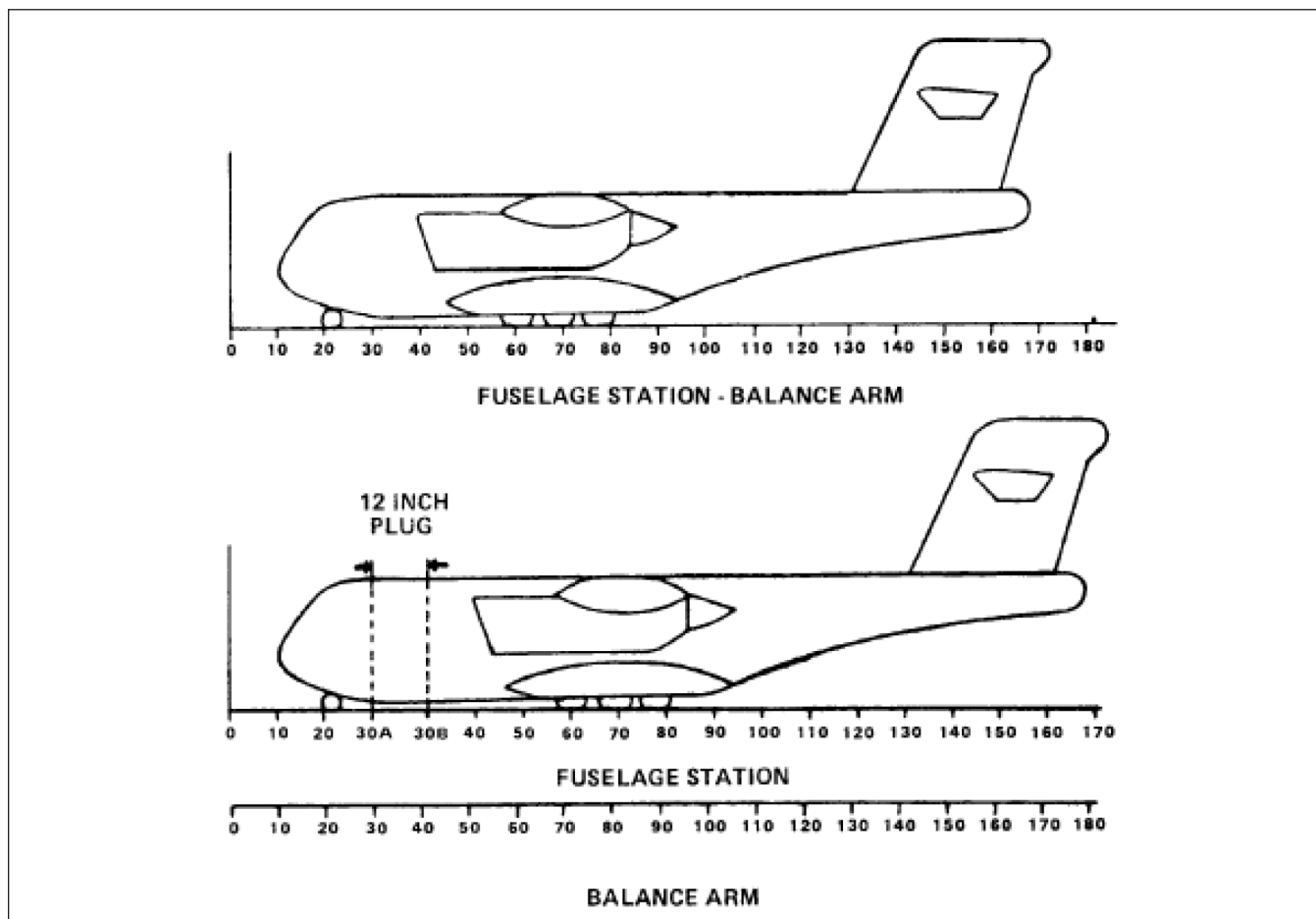

Figure 2-3. Balance Arm Fuselage Station

2.5 PERCENT MEAN AERODYNAMIC CHORD (% MAC). In fixed-wing aircraft, the location of the aircraft CG is commonly expressed by %MAC instead of by its balance arm. The Mean Aerodynamic Chord (MAC) is an overall average chord, representative of an entire wing, used in aerodynamic computations and analysis. Expressing the CG in %MAC identifies where the CG is relative to this mean chord of the wing. Zero %MAC is the leading edge of the average chord and 100 %MAC is the trailing edge of the average chord. For definitions, see Appendix A. For weight and balance purposes, %MAC is found by a simple mathematical conversion equation or tables particular to the aircraft type, and is listed in the aircraft-specific loading manual. (See Figure 2-4).

2.6 LOADING/UNLOADING. The loading or unloading of items can have a considerable effect on aircraft balance, even when the items total less than one tenth

of one percent of the aircraft weight. Balance loading principles and the techniques for determining the CG for various aircraft configurations are discussed in Chapter 7 (Center of Gravity Loading Calculations).

2.7 BALLAST. There are two types of concentrated masses, permanent ballast and temporary ballast, that can have a profound effect on aircraft balance and therefore must be accounted for accurately. Permanent ballast is required by design of the aircraft or due to modifications and must be installed before flight. Temporary ballast may be required to be installed before flight depending on operational loading conditions. For definitions of permanent and temporary ballast, see Appendix A. An equation for use in determining the amount of temporary ballast is included in Chapter 7 (Center of Gravity Loading Calculations).

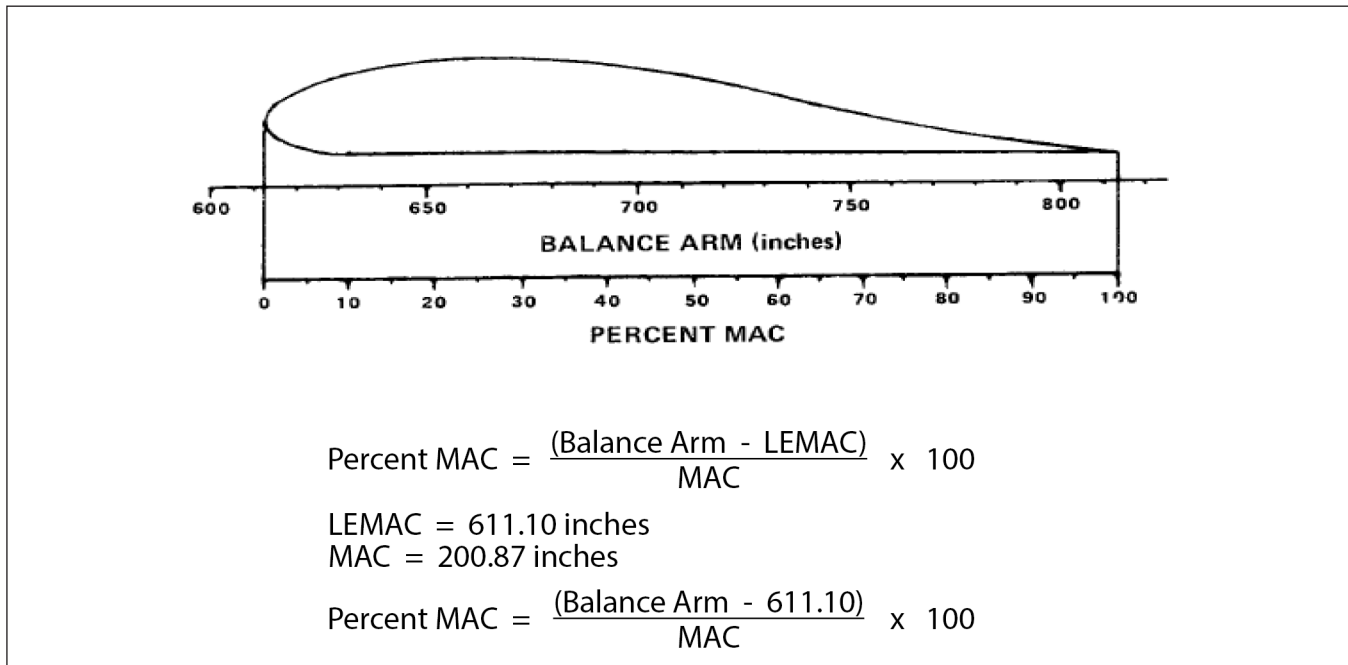

Figure 2-4. Percent MAC Example

CHAPTER 3 WEIGHT AND BALANCE SYSTEM

3.1 GENERAL. This Chapter defines the requirements, procedures and Command responsibilities relative to the US Military aircraft weight and balance control system. The overall objectives of the system are to provide current and correct information regarding aircraft Basic Weight and moment, and to maintain aircraft Gross Weight and CG within permissible limits in order to ensure safety of flight. Responsibilities for weight and balance personnel qualifications are identified in service specific portions of Chapter 8.

3.2 MANUFACTURER RESPONSIBILITIES.

3.2.1 The aircraft manufacturer inserts all identifying aircraft data on the title page of the Weight and Balance Handbook and completes all other applicable charts and forms prior to delivery of the aircraft.

3.2.2 The aircraft manufacturer or commercial modification facility shall maintain and update the aircraft Weight and Balance Handbook in accordance with this manual. Any associated electronic records in equivalent format shall be updated as well prior to delivery or return to service.

3.2.3 Each service's technical proponent for weight and balance may approve alternate methods, in lieu of weighing every new aircraft, for the manufacturer to establish the initial weight and center-of-gravity. (See Chapter 8 - Service Specific Requirements).

3.3 COMMERCIAL MAINTENANCE RESPONSIBILITIES. Commercial activities involved in the weight and balance control of US Military aircraft shall comply with requirements of this manual when this manual is invoked in the contract.

3.4 DEPOT/INTERMEDIATE LEVEL MAINTENANCE RESPONSIBILITIES. Depot / Intermediate level maintenance facilities shall update individual aircraft Weight and Balance records and weigh aircraft as required in accordance with the requirements of this manual and other applicable service specific documents (see Chapter 8 - Service Specific Requirements). These facilities shall ensure that a dedicated staff of qualified personnel are available to accomplish the required tasks and shall designate the Lead Weight and Balance Specialist responsible.

3.5 AIRCRAFT CUSTODIAN/TECHNICIAN/TYPE COMMANDER RESPONSIBILITIES. Refer to Chapter 8 - Service Specific Requirements for additional clarification of responsibilities.

3.6 AIRCRAFT WEIGHT AND BALANCE CLASSIFICATIONS. For weight and balance control purposes, US Military aircraft are divided into the following classifications:

3.6.1 Class 1A. Class 1A aircraft are those with published weight and CG limits that cannot be exceeded by normally employed loading arrangements and therefore need no loading control.

3.6.2 Class 1B. Class 1B aircraft are those with published weight and CG limits that can be exceeded by normally employed loading arrangements and therefore need loading control.

3.6.3 Class 2. Class 2 aircraft are those with published weight and CG limits that can readily be exceeded by normally employed loading arrangements and therefore need a higher degree of loading control.

NOTE

Service-unique requirements for UAVs/UASs are addressed in Chapter 8 - Service Specific Requirements.

3.7 WEIGHT AND BALANCE HANDBOOKS. An aircraft weight and balance handbook provides for the continuous record of the weight and balance data for a particular aircraft. A separate handbook shall be produced and maintained for each active aircraft.

3.7.1 Maintenance of weight and balance handbooks for inactive aircraft (flyable temporary storage, static display, ground training) is not required but they should be retained. If inactive aircraft become active, the weight and balance handbook shall be updated with an actual weighing prior to return to flight. If the weight and balance handbook is not available, one shall be initiated in accordance with paragraph 3.7.5.

3.7.2 Handbook Location. Weight and balance handbooks shall be stored as determined by the aircraft custodians/technicians, but always in a location readily available to the pilot and other personnel responsible for accomplishing weight and balance functions.

NOTE

For some aircraft it may be possible to have a completely electronic Weight and Balance handbook if authorized or required for a particular aircraft platform or by the appropriate governing authorities for each service.

3.7.3 Handbook Content. The weight and balance handbook shall be maintained for each assigned active aircraft by qualified weight and balance personnel. The handbook DD 365 series charts, forms and records (or electronic equivalents), shall be maintained in accordance with requirements and instructions of this manual. The contents of the weight and balance handbook shall include:

3.7.3.1 A cover page containing the aircraft type Model/Design/Series/Type/Model/Series (MDS/TMS) and aircraft number (serial number/bureau number (BUNO)) shall be used if the handbook is maintained using paper forms.

3.7.3.2 DD Form 365, Record of Weight and Balance Personnel.

3.7.3.3 DD Form 365-1, Chart A - Basic Weight Checklist Record.

3.7.3.4 DD Form 365-2, Form B - Aircraft Weighing Record.

3.7.3.5 DD Form 365-3, Chart C - Basic Weight and Balance Record.

3.7.3.6 Chart E - Loading Data for applicable aircraft. (See Chapter 8 - Service Specific Requirements).

3.7.3.7 Required copies of DD Form 365-4, Weight and Balance Clearance Form F, except Class 1A aircraft.

3.7.3.8 Electronic Media. When an aircraft is transferred, the transferring activity shall ensure an AWBS data file (or equivalent) for that serial number aircraft in a suitable approved electronic format is included with the weight and balance handbook records transferred with the aircraft.

3.7.3.8.1 The electronic weight and balance file shall be backed up. (See Chapter 8 - Service Specific Requirements). The data file shall be backed up in a location other than that of primary storage.

3.7.4 Handbook Security Classification. Aircraft weight and balance handbooks shall be classified in accordance with the highest security classification of the data contained therein. Contact local or program security officers for additional requirements.

3.7.5 Handbook Initiation or Replacement. In the event an aircraft weight and balance handbook or pages become lost, damaged, or for any reason need to be initiated or replaced, the individual assigned responsibility for that aircraft weight and balance handbook shall assemble a new handbook as follows:

3.7.5.1 A cover page inserted in a blank binder or suitable equivalent containing the aircraft type (MDS/TMS) and aircraft number (serial number/bureau number (BUNO)) shall be used if the handbook is maintained using paper forms.

3.7.5.2 Complete a new Record of Weight and Balance Personnel.

3.7.5.3 Create or obtain a new Chart A using an applicable existing Chart A or obtain a copy from the Service Engineering Organization.

3.7.5.4 Inventory the aircraft in accordance with instructions in Chapter 4 (Instructions for the use of Weight and Balance Charts and Forms).

3.7.5.5 Weigh the aircraft by an authorized source. Sources other than an authorized weighing facility shall be approved by the Service Engineering Organization. (See Chapter 8 - Service Specific Requirements). Record the results of the weighing on a Form B.

3.7.5.6 Create a new Chart C and begin it with an initial entry reflecting the newly created Form B. Include a note identifying the reason for assembling a new handbook in the Chart C.

3.7.5.7 Copy an applicable aircraft Chart E from the handbook of another aircraft of the same TMS/MDS or obtain a copy from the Service Engineering Organization. (See Chapter 8 - Service Specific Requirements).

3.7.5.8 Obtain and prepare required Forms F.

3.7.5.9 Create a backup of the AWBS data file (or equivalent) that contains the handbook data, once established and up-to-date.

NOTE

If sufficient data is available to accurately reflect the aircraft's lost or damaged weight and balance data pages, as in the case of worn or water damaged pages, accomplish items 3.7.4.1 through 3.7.4.9 above as deemed necessary by the individual assigned responsibility for weight and balance. This may require obtaining a recent Chart A and Form B from the last weighing and making all applicable changes to the Chart C via a complete inventory and verification of all modifications Time Compliance Technical Order/Modification Work Order/Technical Directive (TCTO/MWO/TD) made since the last weighing. This is only possible if changes since the last weighing are known with full confidence. Electronic forms data (or equivalent) can also be used to create a replacement copy of the lost paper aircraft handbook.

3.7.5.10 Authorized Substitute Forms. Hard copies of an electronic equivalent may be used in lieu of the DD Form 365 charts, forms, and records. (See Chapter 8 - Service Specific Requirements).

3.7.6 Entry Errors. If errors are found on paper forms in the weight and balance handbooks, do not erase or change the entry. With paper forms, line out the erroneous entry and correct the entry. Make a note in the Chart C pertaining to the correction.

3.7.7 Supply of Forms. DD 365 series manual forms are available for download in a fillable PDF document at the DOD Forms Management website at https://www.esd.whs.mil/Directives/forms/dd0001_0499/.

3.7.8 Charts / Forms / Records Disposition. Charts, Forms and Records shall be maintained in accordance with Chapter 8 - Service Specific Requirements.

3.8 WEIGHT AND BALANCE FLIGHT CLEARANCE.

Weight and balance flight clearances are required for aircraft that can exceed weight and balance limits to ensure that operations remain within proper limits during all phases of the mission from ramp/taxi to landing. Such clearance is recorded through the use of the Weight and Balance Clearance Form F, or through an authorized electronic substitute. The original copy of the Form F, when properly signed and filed in accordance with applicable procedures stated in this manual and other service directives, serve as the record to certify that weight and balance flight clearance was properly accomplished. (See Chapter 8 - Service Specific Requirements).

3.8.1 Required Clearance. Weight and balance flight clearance is required for Class 1B and Class 2 aircraft.

3.8.2 Form F Maintenance Procedures. All Forms F shall be completed in accordance with the instructions of this technical manual. Forms F are utilized on a ONE TIME USE basis, or are standardized for multiple uses.

3.8.3 One Time Use Form F. These are Forms F prepared for use on a one-time basis and are kept on file for 90 days upon mission completion or in accordance with command procedures. They are used when the Command does not utilize a standardized loading approach or when an aircraft is loaded in a manner for which no standard loading Form F is on file or applicable. (See Chapter 8 - Service Specific Requirements).

3.8.4 Standardized Loading (formerly CANNED) Form F. These are Forms F prepared for "repetitive use." They are filed in accordance with established Command procedures for future reference and use. Forms F based on standardized loadings shall be checked at least every 180 days for accuracy and a new Form F prepared as required. (See Chapter 8 - Service Specific Requirements). If no changes are required, the Form F may be re-dated and initialed, or a letter issued to state the review has been accomplished to certify its currency.

3.8.5 Clearance Procedure. When filing DD Form 175, Military Flight Plan (or authorized substitute), the basis for weight and balance flight clearance shall be noted. For ONE TIME USE Forms F, attach the original form to the flight plan, retain a copy with the aircraft until flight termination, and retain a copy in the weight and balance handbook with the aircraft custodian/technician for 90 days upon mission completion or in accordance with command procedures. For Forms F based on

Table 3-1. Major Modification or Repair Guideline

Basic Weight (Pounds)	Weight Affected by Major Mod as Percent of Basic Weight	CG Change, Fixed-Wing (%MAC or Index)	CG Change, Rotary-Wing (Inches)
0-5,000	2.0%	0.5	0.5
5,001-50,000	1.5%	0.5	0.5
> 50,000	1.0%	0.2	0.2

standardized loadings, retain the forms in the weight and balance handbooks until superseded.

3.8.6 Authorized Substitutions For DD Form 365-4. The following substitutes are authorized for use as weight and balance clearance records in lieu of DD Form 365-4.

3.8.6.1 Computer output sheets when the data recorded is identical to that required on the DD Form 365-4.

3.8.6.2 The designated commercial type loading schedule for C-9 and C-40 aircraft.

3.8.6.3 Other Commercial loading schedules approved by the appropriate Service Engineering Organization.

3.8.6.4 Computer programs that replicate the DD Form 365-4 forms shall follow the requirements in Chapter 6, paragraph 6.2 of this Technical Manual.

3.9 AIRCRAFT WEIGHING REQUIREMENTS. Aircraft shall be weighed when any of the following conditions exist:

a. As required by pertinent service directives or technical directives.

b. In accordance with weighing requirements specified in applicable aircraft loading manual, operators manual or Chart E.

c. After completion of selected depot level events as defined by appropriate Service Engineering Organization.

NOTE

Selected depot level events include the replacement of major structural members such as spars, wings, tail booms

d. When major modifications or repairs are made:

(1) The weight and balance technician/custodian or appropriate Service Engineering Organization authority shall determine when an aircraft has undergone a "major modification or repair". As a guideline, a major modification or repair is one that affects the Basic Weight to an extent that exceeds the thresholds as reflected in Table 3-1. (See Chapter 8 - Service Specific Requirements).

e. When aircraft modifications or repairs are accomplished and calculated or actual weight and moment data for the modification is not available or reliable. Weight and moment changes for items affected by a modification or repair may not be known for in-service aircraft.

f. When an aircraft is completely stripped and repainted or additional layer(s) of paint is added to the entire aircraft. Consult Service Engineering Organization for guidance when aircraft are partially painted.

g. When the weight and balance data is suspected to be in error.

h. When unsatisfactory flight characteristics are reported that cannot be determined to be the result of improper aircraft loading, an error in weight and balance data, or any other identifiable cause.

i. Whenever inactive aircraft become active as described in paragraph 3.7.

j. When the weight and balance handbook needs replacement and sufficient data is not available to accurately reflect the aircraft's lost or damaged weight and balance data pages, as described in paragraph 3.7.

CHAPTER 4
INSTRUCTIONS FOR THE USE OF WEIGHT AND BALANCE CHARTS AND FORMS

4.1 FORM RETENTION AND DISPOSITION.

4.1.1 See Chapter 8 - Service Specific Requirements for retention/disposition requirements.

4.2 DD FORM 365: RECORD OF WEIGHT AND BALANCE PERSONNEL OR ELECTRONIC EQUIVALENT.

4.2.1 This form is a continuous record of weight and balance personnel (civilian or military) responsible for the correctness and maintenance of an aircraft's weight and balance handbook. It lists the name, grade/rate/rank, where and when qualified, duty station, date of initial responsibility for maintaining the weight and balance records, and date responsibility was relieved. Other qualified personnel may make entries in the weight and balance handbook if they have been designated to do so by the individual currently assigned responsibility for the handbook. The last line entry shall indicate the person who is currently responsible for maintaining the weight and balance handbook at all times.

4.3 DD FORM 365-1: CHART A – BASIC WEIGHT CHECKLIST RECORD OR ELECTRONIC EQUIVALENT.

4.3.1 There are three primary purposes of the Chart A. The first is to provide a definition of what is included in Basic Weight for a particular aircraft. The second is to provide weight and balance data for items that may be removed from or added to the Basic Weight of the aircraft. The third purpose is to facilitate the inventory process.

4.3.1.1 The Chart A consists of a list of equipment and the equipment weight, arm, and simplified moment that is installed or is approved for installation and is part of the aircraft's Basic Weight. Items that are readily removable, not necessary for flight, and identifiable are suitable Chart A items. Safety of Flight required items may be listed if their data is required to perform aircraft weighings. Items shall be listed on the Chart A as separate entries, suitably identified in order to facilitate an inventory of equipment. Items shall be listed by descriptive name or type, part number or equipment designation (if visible during inventory), capacity, and other appropriate means to avoid ambiguity and to facilitate identification and inventory. The weight and arm shall reflect the Line

Table 4-1. Minimum Weight Threshold Guideline for Chart A Items

Basic Weight (pounds)	List Items In Chart A That Weigh Greater Than Or Equal To:
Less than 5,000	1 pound
5,000 to 50,000	2 pounds
Greater than 50,000	5 pounds

Replaceable Unit (LRU) weight and arm. Equipment which are alternates to each other shall be suitably identified, e.g., "(alternate to item A-21)" or similar. If an item can be located in alternate positions (e.g. "stowed" or "installed"), the item shall be listed for both locations and so labeled. Table 4-1 identifies guidelines for determining suitable minimum item weight thresholds for listing items in Chart A in addition to other criteria discussed. Items that do not meet these guidelines may be listed if it facilitates the aircraft inventory process or should be accounted for during an inventory.

4.3.1.2 Alternate items shall be listed as a suffix of the primary item. For example, if a primary item is A-015.00, but there exist several alternate items that may be installed in the same location, the alternates shall be listed as A-015.XX where XX is any value from .01 to .98 and identified as alternates to item A-015.00.

4.3.1.3 Aircraft compartments shall be designated by capital letters and appropriate descriptive nomenclature. The compartment letter designation and name shall be shown at the top of each list of equipment items for each compartment. In DD Form 365-1 (paper) form compartment designation shall be underlined and separated from the equipment list by a blank line. Designated limits of each compartment, in inches from the reference datum, shall be included in the compartment description. Compartment limits should agree with those shown in the aircraft loading manual. External equipment compartment(s) are exempt from designating limits of the compartment. Equipment located external to body compartments, e.g., in wings, nacelles, shall be listed at the end of Chart A under appropriate designations. Illustrations of Chart A item locations should be kept with the Chart A to facilitate the inventory process.

4.3.1.4 The order in which items are listed shall facilitate conducting the inventory. The balance arms should increase progressively from forward to aft in a compartment. If a floor or partition divides a compartment into distinct sections, the Chart A items for that compartment shall be listed by sections. No item or group of items shall be listed in a compartment unless the installed location of the item or group falls within the compartment. Items shall be numbered sequentially by compartment.

4.3.1.5 Weights, moments, and arms should be listed to at least one decimal place. Moments can be simplified by a constant (10; 100; 1,000; 10,000; 100,000).

4.3.2 A Chart A inventory shall be performed whenever:

4.3.2.1 The aircraft is transferred to a new custodian/ technician. The receiving activity shall inventory the aircraft to ensure the Chart A is accurate (optional for USAF aircraft). The transferring activity may inventory the aircraft if desired or if mandated by local requirements.

4.3.2.2 As required by pertinent service directives or modifications. (See Chapter 8 - Service Specific Requirements).

4.3.2.3 The pilot reports unsatisfactory flight characteristics with weight and/or balance implications.

4.3.2.4 The aircraft is weighed.

NOTE

PAPER FORMS – when using DD 365-1 forms make a header entry in DD 365-3 Chart C providing the Date of the Inventory in the Date Column and in the Description Column enter “Inventory completed this date by (name)”.

4.3.3 The Chart A shall be updated whenever:

4.3.3.1 The aircraft is inventoried.

4.3.3.2 The aircraft is weighed.

4.3.3.3 The aircraft is received. (optional for USAF aircraft).

4.3.3.4 As directed by a pertinent service directive or aircraft modification instruction.

4.3.3.5 As modifications or configuration changes are made to the aircraft affecting, adding, or deleting Chart A items.

4.3.4 At the time of delivery, the manufacturer inserts the designation of the aircraft's TMS/MDS and Serial Number/BUNO in the spaces provided at the top of the Chart A. The manufacturer marks the IN AIRCRAFT column to indicate the items of equipment in the aircraft for the delivery condition. This delivery inventory reflects the equipment status consistent with the aircraft's initial Basic Weight and Moment as listed on the Chart C.

4.3.5 All Chart A inventories subsequent to the manufacturer's delivery inventory shall be completed as follows:

4.3.5.1 Inspect the aircraft for equipment actually installed. Record the date and location at which the inventory was completed. If the inventory is completed for an actual weighing, the date shall match the date on the Form B. For DD 365-1, place a check in the IN AIRCRAFT column to indicate the presence of an item or a zero to indicate absence. If a partial quantity of an item is present at the time of inventory, make appropriate Chart A and Chart C entries to ensure that the Chart C Basic Weight corresponds to the configuration of the aircraft. Do not mark the item as IN AIRCRAFT unless the item is fully installed. If the aircraft is weighed in a dry condition, this NOTE does not apply.

NOTE

Trapped fuel should be listed in COLUMN I of Form B, if applicable, as it is not part of Basic Weight. Unusable fuel should be listed in COLUMN II. (See Chapter 8 - Service Specific Requirements).

4.3.5.1.1 If trapped fuel is listed on the Chart A, it shall not be marked as IN AIRCRAFT.

4.3.5.1.2 If unusable fuel is listed on the Chart A, it shall be marked as IN AIRCRAFT.

4.3.5.1.3 Adjustments to Basic Weight for the fuel condition at the time of weighing shall be made in COLUMNS I and II of the Form B.

4.3.5.2 During an inventory, note whether any new items or equipment have been installed or previous items permanently removed from the aircraft. For new Chart A items, enter an item number, the name or description (include pertinent information such as date entered and/or service directive number), weight, arm, and moment data. Chart A item numbers shall never be re-used. For permanently removed items, mark the item as not IN AIRCRAFT, and change the description to indicate that the item has been permanently removed, and why such as a service directive. Preserve alternate items if still in use. If an alternate item will be permanently installed, follow the numbering convention specified in paragraph 4.3.1.2. Identify the location where the inventory was performed and the date of the inventory in the Record of Checking column header on DD 365-1 forms.

NOTE

PAPER FORMS - When using manual DD FORM 365-1 Forms, marks in the IN AIRCRAFT and CHART C ENTRY columns are made only at the time of a complete inventory. Never change the marks or add new ones under a previously accomplished inventory.

4.3.5.3 When using DD Form 365 forms, compare this new inventory with the last completed inventory, noting any changes in the items or quantities of equipment installed in the aircraft. Refer to Chart C to ascertain whether the necessary weight and moment corrections have been made. If so, place check marks opposite such items in the CHART C ENTRY column of Chart A. If not, correct the calculated Basic Weight and moment data on Chart C, using the date of the inventory, and then enter the CHART C ENTRY column check marks. A check mark in the CHART C ENTRY column indicates the appropriate weight and moment change has been recorded on the Chart C. To assist with this procedure between inventories, when a Chart A item is added or removed from the aircraft, enter, in pencil, the date removed/installed, in the ITEM DESCRIPTION column of the Chart A. After a complete inventory, erase all existing pencil entries made in the ITEM DESCRIPTION columns.

4.3.6 The procedures for applying a replacement Chart A is as follows:

4.3.6.1 DD 365-1 Replacement Procedures: When replacing an existing DD 365-1 Chart A follow the following steps:

4.3.6.1.1 Ensure the old Chart A is correct and maintained/isolated to ensure traceability to the last weighing. After the next subsequent aircraft weighing and posting to Chart C, the old Chart A may be discarded.

4.3.6.1.2 Copy the latest inventory data, to the greatest extent possible, from the previous old Chart A into Column 1 of the new Chart A.

4.3.6.1.3 Make a header entry in Chart C specifying that a new Chart A was applied this date and Column 1 inventory data was taken from the previous Chart A.

4.4 DD FORM 365-2: FORM B -AIRCRAFT WEIGHING RECORD OR ELECTRONIC EQUIVALENT.

4.4.1 The purpose of the Form B is to record the data obtained from an actual aircraft weighing. This form also provides the necessary instructions for computing the current weight, moment and center of gravity (CG) of the aircraft.

WARNING

The Form B is the only time in which un-simplified moments are employed when the aircraft has a constant assigned.

NOTE

Instructions for weighing aircraft are in the aircraft specific manuals or in Chapter 5 (Weighing Aircraft) of this manual.

4.4.2 Use of weighing worksheets is recommended for recording measurement results when using electronic forms.

4.4.3 The following are instructions for completion of the Form B:

4.4.3.1 Fill in the Form B header information.

4.4.3.2 Identify the reaction points used in the REACTION column (wheels or jack-points).

4.4.3.3 Enter the as-weighed weight data in the SCALE READING column for each reaction.

4.4.3.4 In the separate CORRECTIONS block, enter the corrections necessary for each of the reactions:

4.4.3.4.1 Calibration corrections are determined by the calibration laboratory, if applicable.

4.4.3.4.2 Scale correction factor is required when the scale does not return to zero after the load is removed from the scale. If the scale is unloaded and returns a value other than zero, the scale correction factor is that same number but of opposite sign. If the scale returns a negative value, the scale correction factor must be positive. If the scale returns a positive value, the scale correction factor must be negative.

4.4.3.4.3 Scale operating instructions will specify gravitational or latitude correction factors and temperature correction factors, if applicable

4.4.3.4.4 Equipment corrections such as chocks, blocks, slings, and jacks included in the scale reading to be subtracted from the scale reading.

4.4.3.4.5 Enter any other appropriate corrections.

4.4.3.5 Total the corrections block for each reaction and use these values in the CORRECTIONS column for each reaction.

4.4.3.6 Sum the SCALE READING and CORRECTIONS block to obtain the NET WEIGHT for each reaction.

4.4.3.7 Dimensions E and F shall be obtained and entered in both the MEASUREMENTS Section and the ARM column. When the aircraft is weighed on wing and/or fuselage jack points, dimensions E and F may be obtained from weighing instructions for the particular aircraft. When weighing the aircraft on wheels or landing gear jack points, the values of E and F shall be calculated by measuring dimensions B, D, and I. Using B, D and I, calculate and enter dimensions E and F in inches.

4.4.3.8 Multiply the NET WEIGHT of each reaction by the ARM to obtain the un-simplified MOMENT of each reaction.

4.4.3.9 Sum the NET WEIGHT and MOMENT columns of all reactions to determine the TOTAL (as weighed) row.

4.4.3.10 Divide the TOTAL MOMENT by the TOTAL NET WEIGHT to obtain the TOTAL ARM of the aircraft before adjustments.

4.4.3.11 In COLUMN I, record the weight and moment of all items in aircraft when weighed, but NOT part of Basic Weight.

4.4.3.12 In COLUMN II, record the weight and moment of all Basic Weight items that were not in the aircraft when weighed.

4.4.3.13 USN/USMC units - see paragraph 8.2.8 regarding COLUMN II entries on Form B.

4.4.3.14 Subtotal Columns I and II.

4.4.3.15 Add the TOTAL NET WEIGHT and MOMENT (as weighed) from the front of the Form B and the totals from COLUMN I and II to determine the BASIC AIRCRAFT NET WEIGHT and MOMENT in the provided section. This shall be posted to the Chart C.

NOTE

The term NET WEIGHT indicates an "as weighed" value including CORRECTIONS.

4.4.3.16 In the SCALE section, fill in SCALE TYPE (make and model), SERIAL NUMBER (of all scales/load-cells used), and DATE CALIBRATED. CALIBRATION ACCURACY block is not used.

4.4.3.17 Identify REACTIONS USED (wheels or jack-points).

4.4.3.18 In the REMARKS Section, enter at a minimum: "Aircraft clean, dry, fuel system condition (dry, trapped, or full using open-port method), fuel density X.X pounds per gallon, (if fuel system is full), weighed in level or non-level condition, aircraft weighed at 0 degrees nose up attitude or x.x degrees nose up attitude, inside enclosed hangar, using jack/load-cells or platform scales. Scale Settings (if applicable): Altitude: _____ and Latitude: _____."

4.4.3.19 Post Basic Weight and Moment to Chart C.

4.4.3.20 For Contractor weighings, include signature of government witness at the bottom of the form if required.

4.5 DD FORM 365-3: CHART C – BASIC WEIGHT AND BALANCE RECORD OR ELECTRONIC EQUIVALENT.

4.5.1 The Chart C is a continuous and permanent history of the aircraft Basic Weight, moment, and CG. Any required change to the aircraft Basic Weight and/or Moment shall be recorded on the Chart C. The last line of the Chart C (aircraft Basic Weight, moment, and CG) is the most current data and the baseline for all subsequent loading calculations on Forms F.

4.5.2 At the time of delivery of a new aircraft, the manufacturer enters the aircraft Basic Weight, Moment, and CG on the Chart C.

4.5.3 Additions and/or subtractions to the Basic Weight, Moment and CG or index on the Chart C shall be accomplished as follows:

4.5.3.1 Whenever Basic Weight items are installed or removed from the aircraft, ensure the change is reflected on the Chart C. If the entry is for a Chart A item, ensure Chart C entry matches the data in Chart A. If the item is not a Chart A item, determine the item's weight, arm, and moment by applicable aircraft modification instructions or actual measurement. Record this data on the Chart C and if applicable add the data to the Chart A.

NOTE

For test/developmental equipment and/or temporary installations/removals, entries may be recorded on the Form F.

4.5.3.2 Subsystem modifications or structural changes and other changes that affect items not listed in Chart A shall be recorded as additions to or removals from Chart C Basic Weight and Moment. For non-Chart A items, values can be grouped and entered on the Chart C as "Structural" or "Electrical" removals and additions. Structural and Electrical changes or provisions for equipment should not be entered on Chart A.

4.5.3.3 Any change that is caused by a specific aircraft modification shall be entered in accordance with the instructions in the modification and shall reference the modification number.

NOTE

When making changes as the result of an aircraft modification instruction: Enter a header to indicate that the following changes are the result of that instruction. Enter applicable Chart A additions and removals, and Chart C additions and removals (utilizing structural and electrical summations). End the modification with a header to indicate completion.

If an aircraft modification instruction does not contain sufficient weight and balance information to properly update the weight and balance records, or the instruction for updating the weight and balance records are in error (e.g. no instruction to add/remove Chart A equipment to/from the Chart A or incorrect instruction to add non Chart A equipment to the Chart A), notify the Service Engineering Organization.

For DD 365-3, whenever a new Master Chart A is applied, enter a Header on the Chart C briefly explaining the event.

4.5.3.4 Whenever a Chart A inventory or inspection reveals that equipment changes, subsystem modifications, or structural changes have been made to the aircraft but were not properly recorded in the Chart C, the change to Basic Weight and moment shall be posted in Chart C as required in the preceding paragraphs. The newly calculated Basic Weight, moment and arm (or index) shall be dated to agree with the inventory date entered on the Chart A.

4.5.3.5 Whenever an aircraft is weighed, the Chart C shall be updated to show the new Basic Weight, simplified moment, and arm (or index) from the Form B. The date entered on the CHART C shall agree with the inventory date entered on the Chart A and the weighing date entered on Form B.

4.5.3.6 When the Chart C Basic Weight is changed by +/- 0.3%, or Basic CG is changed by +/- 0.3 inches, a new Form F which reflects this change must be prepared. (See Chapter 8 - Service Specific Requirements for Temporary Changes).

4.6 CHART E – AIRCRAFT LOADING MANUAL / WEIGHING INSTRUCTIONS.

4.6.1 The Chart E provides the aircraft specific information necessary to load and weigh the aircraft (i.e. weighing configuration, draining instructions, etc.) and weight and moment data for mission load items necessary to prepare the Form F for the aircraft (i.e. center of gravity limits and the weights and moments of all variable load items).

4.6.2 Aircraft without Chart E weighing instructions may use the general weighing instructions contained in this manual.

4.7 DD FORM 365-4: WEIGHT AND BALANCE CLEARANCE FORM FOR ELECTRONIC EQUIVALENT.

4.7.1 The Form F is the summary of the actual disposition of the load carried by the aircraft. It is the official record of the computations done by weight and balance personnel to ensure the weight and CG limits are not exceeded at takeoff, during flight, and at landing due to loading conditions. Weight and moment data necessary for completion of Form F are found in Chart E.

WARNING

All moments on the Form F are simplified moments unless the aircraft does not use a moment simplifier.

NOTE

It is acceptable for weight and moment values on Form F to be expressed as whole numbers. Electronic equivalent forms may use added precision if the system enables it.

4.7.1.1 There are two versions of the Form F, TRANSPORT and TACTICAL. They are designed to provide for the loading arrangements of these two respective types of aircraft/mission. The general use and fulfillment of either version is the same, although separate instructions for filling out each version are provided herein. In the case of multi-purpose aircraft, the choice of which version to use shall be the responsibility of assigned weight and balance personnel. After completion, the Form F shall be filed in accordance with local procedures or applicable service instructions.

4.7.1.2 Normally, only items not included in Basic Weight shall be entered on the Form F.

4.7.2 TRANSPORT FORM F. The following instructions illustrate the use of Chart E data for completion of the Transport Form F. If a load adjuster is used in lieu of the Chart E, enter the load adjuster plate number in the appropriate block and use index values in lieu of simplified moments throughout the form. For simplicity, the following instructions refer to entering weight and moment data; however, index values are entered and summed in the same manner as moments. See Chapter 6 (Weight and Balance Tools) for instructions regarding the use of a load adjuster in completing a Form F.

4.7.2.1 Enter the necessary identifying information on the top of the form.

4.7.2.1.1 DATE: Enter the date the Form F was created or the date it was last recertified.

4.7.2.1.2 MISSION: Enter the name of the mission.

4.7.2.1.3 AIRCRAFT TYPE: Enter the MDS/TMS of the aircraft.

4.7.2.1.4 SERIAL NO: Enter the aircraft's Serial Number or BUNO as applicable.

4.7.2.1.5 FROM: Enter the departure site. This may also be expressed as the International Civil Aviation Organization (ICAO) airfield identifier.

4.7.2.1.6 TO: Enter the arrival landing site. This may also be expressed as the ICAO.

4.7.2.1.7 HOME STATION: Enter the Unit/Activity assigned.

4.7.2.1.8 PILOT: Enter the Pilot's name/rank for One Time Use forms. Enter As Assigned for standardized forms.

4.7.2.1.9 INDEX OR MOM: Enter Index or the simplifier constant utilized on the form.

4.7.2.2 REF 1. BASIC AIRCRAFT: Enter the aircraft Basic Weight and moment (or index) obtained from the last entry on the Chart C.

4.7.2.3 REF 2. If oil is not included in Basic Weight, enter "OIL" and the number of gallons in the ITEM description column, and the weight and moment of the appropriate oil quantity.

4.7.2.4 REF 3. CREW: Enter the number, weight and moment of the crew. Use actual crew weights as required. Always use actual crew locations.

4.7.2.5 REF 4. CREW'S BAGGAGE: Enter the weight and moment of the crew's baggage.

4.7.2.6 REF 5. STEWARD'S EQUIPMENT: Enter the weight and moment of any steward's equipment not included in aircraft Basic Weight.

4.7.2.7 REF 6. EMERGENCY EQUIPMENT: Enter the weight and moment of any emergency equipment not included in aircraft Basic Weight.

4.7.2.8 REF 7. EXTRA EQUIPMENT: Enter the weight and moment of any extra equipment not included in Basic Weight.

4.7.2.9 REF 8. Enter total weights and moments of any additional or operating items.

4.7.2.10 REF 9. OPERATING WEIGHT: Enter the sum of the weights and moments of REF 1 through REF 8.

NOTE

When utilizing electronic forms, OPERATING WEIGHT also includes CORRECTIONS.

4.7.2.11 REF 10. TAKEOFF FUEL: Enter the total number of gallons, and total weight and moment of the fuel on board at takeoff. List under REMARKS the fuel tanks affected and the amount of fuel in each tank (as required). Also list type of fuel, and fuel density.

4.7.2.12 Utilizing the paper form, the weight of fuel used during warm up and/or taxi shall not be included in TAKEOFF FUEL. Utilizing electronic forms, REF 10 refers to total usable fuel in the aircraft prior to engine start.

4.7.2.13 REF 11. WATER INJECTION: Enter the total number of gallons, and total weight and moment of water injection fluid.

4.7.2.14 REF 12. TOTAL AIRCRAFT WEIGHT: Enter the sum of the weights and moments of REF 9 through REF 11, to obtain the TOTAL AIRCRAFT WEIGHT and MOMENT.

4.7.2.15 LIMITATIONS. The Maximum Allowable Gross Weights for Takeoff, Landing, Zero Fuel, Limiting Wing Fuel and/or ground handling restrictions are listed in Chart E as applicable. The smallest of the following resulting conditional allowable loads is the maximum allowable load, and represents the maximum amount of payload that may be distributed throughout the aircraft in various compartments without exceeding the limiting Gross Weights of the aircraft. The conditional allowable loads are computed in the LIMITATIONS table on the lower left-hand corner of the Form F as follows:

NOTE

When utilizing electronic forms, the Maximum Allowable Weight is also based on the Ramp Weight or Maximum Taxi Weight Limit.

4.7.2.15.1 Enter the Maximum Takeoff Weight in the ALLOWABLE GROSS WEIGHT for TAKEOFF block. Determine the allowable load for takeoff by subtracting the TOTAL AIRCRAFT WEIGHT (REF 12) from the Maximum Takeoff Weight. Enter in the ALLOWABLE LOAD for TAKEOFF block.

4.7.2.15.1.1 When utilizing the paper form, if the aircraft has a Maximum Taxiing or Ground Handling Gross Weight (Ramp Weight Limit), determine both the Allowable Load for Takeoff and Allowable Load for Ground Handling, and enter the more restrictive in the first column of the LIMITATIONS table. To determine the Allowable Load for Ground Handling, add the warm-up and/or taxi fuel weight to the TOTAL AIRCRAFT WEIGHT (REF 12), and subtract the resulting weight from the Maximum Ground Handling Gross Weight. An appropriate entry shall be made in the REMARKS Section noting this limiting factor.

NOTE

When utilizing electronic forms, enter the Maximum Ramp Weight, Maximum Landing Weight, Maximum Catapult Weight, Maximum Arrested Landing Weight, Maximum Zero Fuel or Zero Wing Fuel Weight, and all other applicable weight limits in the LIMITATIONS section.

4.7.2.15.2 Enter the Maximum Landing Weight in the ALLOWABLE GROSS WEIGHT for LANDING block. Determine the allowable load for landing by adding the Operating Weight (REF 9) to the Estimated Landing Fuel Weight (REF 23), and subtracting the resulting weight from the Maximum Landing Weight. Enter in the ALLOWABLE LOAD for LANDING block.

4.7.2.15.3 If the aircraft has a Zero Fuel Weight Limit, enter it in the ALLOWABLE GROSS WEIGHT for Zero Fuel block. Determine the allowable load for zero fuel by subtracting the Operating Weight (REF 9) from the Zero Fuel Weight Limit. Enter in the ALLOWABLE LOAD for Zero Fuel block.

4.7.2.15.4 If the aircraft has a Zero Wing Fuel Weight Limit, enter it in the ALLOWABLE GROSS WEIGHT for Limiting Wing Fuel. Determine the allowable load for zero wing fuel by subtracting the weight of fuel in the wings from the Total Aircraft Weight (REF 12), and subtracting the resulting weight from the Zero Wing Fuel Weight limit. Enter in the ALLOWABLE LOAD for Limiting Wing Fuel block.

4.7.2.15.4.1 If the aircraft has both a Zero Fuel Weight Limit and a Zero Wing Fuel Weight Limit, determine the allowable loads of both and enter the more restrictive in the last column of the LIMITATIONS table. An appropriate entry shall be made in the REMARKS Section noting this limiting factor.

4.7.2.16 REF 13. DISTRIBUTION OF ALLOWABLE LOAD (PAYLOAD): For each compartment, enter the compartment designation or arm, number of passengers, passenger weight, and the weight of the cargo in that compartment. Use the same compartment letter designation as shown on the back of the load adjuster or in the Chart E. Use actual weights if available. Enter the totals for each compartment or item in the WEIGHT column. Enter the corresponding moment obtained from the Chart E or load adjuster. Large cargo items, standard passenger loads, or items loaded on pallets may be entered by a combination of items when the aircraft Chart E specifies that such entries may be made.

4.7.2.16.1 Compartment weight totals shall not exceed compartment weight limits if there are any specified in Chart E.

4.7.2.17 REF 14. See REF 21.

4.7.2.18 REF 15. TOTAL PAYLOAD: Enter the sum of the payload weights and moments. Check the Total Payload Weight against the maximum allowable load determined in the LIMITATIONS table.

NOTE

Aircraft executing an external load or cargo drop missions may require two Forms F; one for the portion of the mission without external load/cargo and one for the portion of the mission with the external load/cargo. The weight and CG limits for external load/cargo drop missions may be different than for non-external load/cargo drop weight and CG limits.

4.7.2.19 REF 16. TAKEOFF CONDITION (Uncorrected): Calculate, and enter, the uncorrected Takeoff Weight and moment by summing the weights and simplified moments of the TOTAL AIRCRAFT WEIGHT (REF 12) and TOTAL PAYLOAD (REF 15). Ensure the uncorrected TAKEOFF CONDITION (REF 16) does not exceed the Maximum Takeoff Weight Limitation.

NOTE

When utilizing electronic forms, REF 16 refers to the Ramp Weight calculation which is the sum of REF 12 and REF 15.

4.7.2.20 REF 17. TAKEOFF CG (Uncorrected): Calculate, and enter, the uncorrected Takeoff CG for the uncorrected Takeoff Weight and simplified moment (REF 16). To complete this calculation, multiply the simplified moment by the appropriate constant and divide that value by the weight.

NOTE

When utilizing electronic forms, REF 17 refers to the Ramp CG calculation.

4.7.2.21 Determine the Forward and Aft CG Limits at the uncorrected Takeoff Condition (REF 16) by calculation or from the CG Limitations table in the aircraft Chart E (or CG Grid on the balance computer). If the uncorrected Takeoff CG (REF 17) is within Takeoff CG Limits, enter the Forward and Aft CG Limits in the PERMISSIBLE CG TAKEOFF blocks of the LIMITATIONS table.

4.7.2.21.1 The weight-simplified moment to CG tables in the CHART E are not accurate enough to use near the forward and aft CG limits. If a CG is read off these tables and it is located one CG interval (the spacing between the listed CG values, such as 0.5, 1.0 or 2.0 percent MAC) from a CG limit, or closer, the CG shall be arithmetically calculated to an accuracy of 0.1 percent MAC.

NOTE

The Chart E CG Limitations table and the CG Grid on the load adjuster usually account for any required adjustment to the CG limit moment values due to retraction of the landing gear. If the Takeoff CG is calculated, refer to the Chart E CG Limitations table notes for any required moment adjustments due to the retraction of the landing gear.

When utilizing electronic forms, the Forward and Aft Ramp CG Limits are determined at the Ramp Weight REF 16.

4.7.2.22 REF 18. CORRECTIONS. If the uncorrected Takeoff Condition (REF 16) and/or the uncorrected Takeoff CG (REF 17) are not within limits, additional changes in the amount or distribution of load and/or fuel are required, and a new or updated Form F shall be completed.

4.7.2.22.1 If a load adjuster is used, the revised index for each correction item, rather than plus or minus index changes shall be entered, and the uncorrected takeoff index (REF 16) should be used as a starting point for all corrections.

NOTE

When utilizing electronic forms, REF 18 refers to taxi fuel and CORRECTIONS are entered prior to the calculation of OPERATING WEIGHT (REF 9).

4.7.2.23 REF 19. TAKEOFF CONDITION (Corrected): Calculate, and enter the corrected Takeoff Weight and moment by summing the weights and moments of the uncorrected TAKEOFF CONDITION (REF 16) and the corresponding CORRECTIONS (REF 18). Ensure the TAKEOFF CONDITION (REF 19) does not exceed the Maximum Takeoff Weight.

NOTE

When utilizing electronic forms, REF 19 refers to TAKEOFF WEIGHT which is a sum of REF 16 and REF 18.

4.7.2.24 REF 20. TAKEOFF CG (Corrected): Calculate, and enter the corrected Takeoff CG at the corrected Takeoff Weight and moment (REF 19).

4.7.2.25 Determine if the forward and aft CG limits have changed at the corrected Takeoff Gross Weight (REF 19) by calculation, or from the CG Limitations table in the aircraft Chart E (or CG Grid on the load adjuster). If the corrected Takeoff CG (REF 20) is within Takeoff CG limits, enter the forward and aft CG limits in the PERMISSIBLE CG TAKEOFF blocks of the LIMITATIONS table.

NOTE

When utilizing electronic forms, enter the Ramp, Takeoff, Landing, Catapult Takeoff, Arrested Landing, Zero Fuel or Zero Wing Fuel CG Limits and all other applicable CG Limits in the LIMITATIONS section.

4.7.2.26 REF 21. ZERO FUEL WEIGHT: Calculate, and enter the Zero Fuel Weight (ZFW), by subtracting the weights and moments of the Takeoff Fuel (REF 10) from the corrected Takeoff Weight (REF 19).

NOTE

When utilizing electronic forms, REF 21 is calculated by subtracting REF 10 from REF 16.

4.7.2.26.1 Transfer the Zero Fuel Weight and moment to the respective REF 14 blocks.

4.7.2.26.2 Calculate and enter the Zero Fuel CG at the Zero Fuel Weight and moment.

4.7.2.26.3 If applicable, determine the forward and aft CG limits at the Zero Fuel Weight, by calculation, or from the CG Limitations table in the aircraft Chart E (or CG Grid on the load adjuster). Enter in the PERMISSIBLE CG ZERO FUEL WT blocks of the LIMITATIONS TABLE.

4.7.2.26.4 If applicable, ensure the Zero Fuel Weight does not exceed the Zero Fuel Weight Limits and/or that the Zero Fuel CG does not exceed the Zero Fuel Forward or Aft CG Limits. Make additional load adjustments if necessary.

4.7.2.27 REF 22. AIR DROP LOAD:

4.7.2.27.1 Enter the weight and moment of any aerial load to be dropped before landing.

4.7.2.27.2 Enter the weight and moment of any miscellaneous items to be expended or added prior to landing. Explain in REMARKS if necessary.

4.7.2.27.3 Enter any crew movement from takeoff to landing positions. Explain in REMARKS if necessary.

4.7.2.28 REF 23. ESTIMATED LANDING FUEL: Enter the Estimated Landing Fuel Weight and moment.

4.7.2.29 REF 24. ESTIMATED LANDING CONDITION: Calculate the Estimated Landing Weight and moment by subtracting the total weights and moments of AIR DROP LOAD (REF 22) from the ZERO FUEL WEIGHT (REF 21) and adding the resulting weight and moment to the ESTIMATED LANDING CONDITION (REF 23) weight and moment, respectively. Ensure that the ESTIMATED LANDING CONDITION (REF 23) weight does not exceed the Maximum Landing Weight.

4.7.2.30 REF 25. ESTIMATED LANDING CG: Calculate and enter the Estimated Landing CG using the weight and moment from the ESTIMATED LANDING CONDITION (REF 24).

4.7.2.31 Determine the Forward and Aft CG Limits at the ESTIMATED LANDING CONDITION (REF 24) by calculation or from the CG Limitations table in the aircraft Chart E (or CG Grid on the load adjuster). If the ESTIMATED LANDING CG (REF 25) is within the landing CG limits, enter the Forward and Aft CG Limits in the PERMISSIBLE CG LANDING blocks of the LIMITATIONS table.

4.7.2.32 If the ESTIMATED LANDING CONDITION (REF 24) weight and/or CG (REF 25) are not within permissible landing weight and CG limits, additional changes in the amount or distribution of load and/or fuel are required, and a new Form F shall be completed.

4.7.2.33 MOST FORWARD & MOST AFT CG CALCULATIONS: In the blocks provided in the upper left-hand portion of the Form F, calculate the most forward and aft CG in flight, unless the CG is monitored during flight. The Chart E may indicate which loading conditions lead to the most forward and most aft CG conditions

during flight. Check the CG Limitations tables of the applicable Chart E, to ensure that the most forward and most aft CG are within the CG limits for flight.

4.7.2.34 When the most forward CG condition and/or the most aft CG condition does not remain within CG limits, additional changes in the amount or distribution of load and/or fuel are required, and a new Form F shall be completed.

4.7.2.35 REMARKS block. Any significant information regarding mission-loading, takeoff, and/or landing conditions that needs to be conveyed to aircraft operators shall be entered in the remarks block.

4.7.2.36 The following signatures are required as noted below:

4.7.2.36.1 COMPUTED BY. The name and signature of the assigned Weight and Balance personnel who computed the form.

4.7.2.36.2 WEIGHT AND BALANCE AUTHORITY. The name and signature of the Weight and Balance Officer, Technician, Custodian, Aircrew, or Authority.

4.7.2.36.3 PILOT. The name and signature of the pilot shall appear on ONE TIME USE Forms F submitted by the pilot or another crew member for flight clearance.

NOTE

The purpose of the pilot name is to indicate the Form F has been checked to be complete and accurate. In case of Forms F based on standardized loadings, the pilot indicates the final check of the form by inserting the appropriate Form F reference on the DD Form 175 (Military Flight Plan).

4.7.3 Tactical Form F. The following instructions illustrate the use of CHART E data for completion of the TACTICAL FORM F. If a load adjuster is used in lieu of the Chart E, enter the load adjuster plate number in the REMARKS block and use index values in lieu of moments throughout the form. For simplicity, the following instructions refer to entering weight and moment data; however, index values are entered and summed in the same manner. See Chapter 6 (Weight and Balance Tools) for instructions regarding the use of a load adjuster in completing a Form F.

4.7.3.1 Enter the necessary identifying information at the top of the form. Refer to paragraph 4.7.2.1.

4.7.3.2 REF 1. BASIC AIRCRAFT: Enter the aircraft Basic Weight and moment (or index) obtained from the last entry on the Chart C.

4.7.3.3 REF 2. If oil is not included in Basic Weight, enter "OIL" and the number of gallons in the description column, and the weight and moment of the appropriate oil quantity.

4.7.3.4 REF 3. DISTRIBUTION OF LOAD: Using the compartment letter designations or Arm as shown on the back of the load adjuster or Chart E, enter the number and weight and moment of the crew at their takeoff positions, baggage, cargo, and all non-expendable items not in the Basic Weight (e.g. pylons, racks, ballast, troop seats, guns, emergency equipment, etc.). Use actual weights and moments if available. Enter the total of each compartment in the Weight and Index or Moment columns. Check against any compartment weight limits in Chart E to ensure that they are not exceeded.

4.7.3.5 REF 4. OPERATING WEIGHT. Enter the sum of the weight and moments of REF 1 through REF 3.

NOTE

When utilizing electronic forms, OPERATING WEIGHT also includes CORRECTIONS.

4.7.3.6 REF 5. AMMO. Enter item description (type, and number of rounds), weight and moment of all ammunition.

NOTE

Electronic forms enable two separate weight and moment entries for ammunition; one for the portion that leaves the aircraft when it is fired and one for the portion that is retained in the aircraft after firing. The weight and moment of ammunition that departs the aircraft is entered as an expendable item. The weight and moment of ammunition that is retained is entered as a non-expendable item.

4.7.3.7 REF 6. BOMBS, MISSILES, ETC: Enter the item description, weight and moment of all items that may be expended during flight. Examples include bombs, torpedoes, countermeasures, and rockets and all ordnance suspension equipment such as launchers,

Pods, and racks which are expendable. Include external auxiliary fuel tanks that are droppable as well.

4.7.3.8 REF 7. FUEL. Enter the weight, and moment of the fuel on board at takeoff. Separate the total fuel as Internal, External and Auxiliary as appropriate. List under REMARKS the fuel tanks affected and the amount of fuel in each tank (as required). Also list the type and density of fuel.

4.7.3.8.1 Utilizing the paper form, the weight of fuel used during warm up and/or taxi shall not be included in TAKEOFF FUEL.

NOTE

Utilizing electronic forms, REF 7 refers to total usable fuel in the aircraft prior to engine start.

4.7.3.9 REF 8. MISC. VARIABLES. Enter the item descriptions, weights, and moments of miscellaneous items.

4.7.3.10 LIMITATIONS. Enter the Maximum Takeoff Weight and Maximum Landing Weight, from the latest applicable Chart E, in the GROSS WEIGHT TAKEOFF and GROSS WEIGHT LANDING blocks of the LIMITATIONS table. Enter the most Forward and most Aft CG Limits in % M.A.C or inches, from the latest applicable Chart E, in the PERMISSIBLE CG TAKEOFF and LANDING sections of the LIMITATIONS table. Ensure the proper limits are utilized for the mission being flown. Some aircraft have different limits when operating from land or shipboard based operations.

4.7.3.10.1 If the aircraft has additional weight or CG limits (e.g. Maximum Zero Fuel Weight) these additional limits shall also be checked. Steps for checking against Maximum Zero Fuel Weight are included on the Transport version of Form F and in the associated instructions herein.

4.7.3.10.2 When utilizing the paper form, if the aircraft has a Maximum Taxiing or Ground Handling Gross Weight (Ramp Weight Limit), determine both the Allowable Load for Takeoff and Allowable Load for Ground Handling, and enter the more restrictive in the first column of the LIMITATIONS table. To determine the Allowable Load for Ground Handling, add the warm-up and/or taxi fuel weight to the TAKEOFF GROSS WEIGHT (REF 9), and subtract the resulting weight from the Maximum Ground Handling Gross Weight. An appropriate entry shall be made in the REMARKS Section noting this limiting factor.

NOTE

When utilizing electronic forms, enter the Maximum Ramp Gross Weight, Landing Gross Weight, Catapult Takeoff and Arrested Landing, Zero Fuel or Zero Wing Fuel Gross Weight limits, and all other applicable weight limits in the LIMITATIONS section.

4.7.3.11 REF 9. TAKEOFF CONDITION (Uncorrected). Calculate, and enter, the uncorrected Takeoff Weight, and simplified moment by summing the weights and simplified moments of REF 4 through REF 8. Ensure the uncorrected Takeoff Condition (REF 9) does not exceed the Maximum Takeoff Weight.

NOTE

When utilizing electronic forms, REF 9 refers to the ramp weight calculations which are the sum of REF 4 through REF 8.

4.7.3.12 REF 10. TAKEOFF CG (Uncorrected). Calculate and enter the uncorrected takeoff CG at the uncorrected takeoff Gross Weight and moment (REF 9).

NOTE

When utilizing electronic forms, REF 10 refers to ramp CG calculations.

4.7.3.13 Determine the forward and aft CG limits at the uncorrected Takeoff Gross Weight (REF 9) by calculation or from the CG Limitations table in the aircraft Chart E (or CG Grid on the balance computer). If the uncorrected takeoff CG (REF 10) is within the Takeoff CG limits, enter the forward and aft CG limits in the PERMISSIBLE CG TAKEOFF blocks of the LIMITATIONS table.

4.7.3.13.1 The weight-simplified moment to CG tables in the CHART E are not accurate enough to use near the forward and aft CG limits. If a CG is read off these tables and it is located one CG interval (the spacing between the listed CG values, such as 0.5, 1.0 or 2.0 percent MAC) from a CG limit, or closer, the CG shall be calculated to an accuracy of 0.1 percent MAC).

NOTE

The Chart E CG table and the CG grid on the load adjuster usually account for any required adjustment to the CG limit moment values due to retraction of the landing gear. If the takeoff CG is calculated, refer to the Chart E CG table notes for any required moment adjustments due to the retraction of the landing gear.

When utilizing electronic forms, the forward and aft ramp CG limits are determined at the Ramp Gross Weight REF 9.

4.7.3.14 REF 11. CORRECTIONS. If the uncorrected weight at the TAKEOFF CONDITION (REF 9) and/or the uncorrected Takeoff CG (REF 10) are not within Takeoff Weight and CG Limits, a change in the amount or distribution of load (REF 3 through REF 8) is required, and the necessary load adjustments shall be noted in the CORRECTIONS column on the left-hand portion of the Form F. Enter a brief description of the necessary load adjustment in the left-hand column with the weight and moment listed in the columns provided. Sum the weights moments of the weight decreases and enter in the TOTAL WEIGHT REMOVED blocks. Sum the weights and sum the moments of the weight increases and enter in the TOTAL WEIGHT ADDED blocks. Sum the resulting totals, to obtain the net weight correction and net moment correction, and enter in the NET DIFFERENCE blocks. Transfer the net weight difference and net moment difference to the CORRECTIONS (If required) blocks. For paper Forms F, Gear Up Moment Change is accounted for in the CORRECTIONS.

4.7.3.14.1 If a load adjuster is used, the revised index for each correction item, rather than plus or minus index changes shall be entered, and the uncorrected takeoff index (REF 10) should be used as a starting point for all corrections.

NOTE

When utilizing electronic forms, REF 11 refers to taxi fuel and CORRECTIONS are entered prior to the calculation of OPERATING WEIGHT (REF 4).

4.7.3.15 REF 12. TAKEOFF CONDITION (Corrected). Calculate and enter the corrected Takeoff Weight and moment by summing the weights and moments of the uncorrected TAKEOFF CONDITION (REF 9) and the net corrections (REF 11). Ensure the corrected Takeoff Weight (REF 12) does not exceed the Maximum Takeoff Weight, and make additional load adjustments as necessary.

NOTE

When utilizing electronic forms, REF 12 refers to the TAKEOFF WEIGHT which is the sum of REF 9 and REF 11.

4.7.3.16 REF 13. TAKEOFF CG (Corrected). Calculate and enter the corrected Takeoff CG using the weight and moment at the corrected TAKEOFF CONDITION (REF 12).

4.7.3.17 Determine if the forward and aft CG limits have changed at the corrected Takeoff Gross Weight (REF 19) by calculation, or from the CG Limitations table in the aircraft Chart E (or CG Grid on the load adjuster). If the corrected takeoff CG (REF 20) is within Takeoff CG limits, enter the forward and aft CG limits in the PERMISSIBLE CG TAKEOFF blocks of the LIMITATIONS table.

NOTE

When utilizing electronic forms, enter the Ramp, Takeoff, Landing, Catapult Takeoff, Arrested Landing, Zero-Fuel or Zero Wing Fuel CG limits and all other applicable CG limits in the LIMITATIONS section.

4.7.3.18 REF 14. TAKEOFF FUEL and LESS EXPENDABLES. Sum the takeoff fuel weights and moments from reference 7 and enter the total weight and moment for TAKEOFF FUEL (REF 14). Sum the weights and moments of expendable items such as ammunition (not including the weight of cases and links if retained), bombs, rockets, torpedoes, and external fuel tanks that are planned to be dropped during flight and enter the subtotals under LESS EXPENDABLES. Explain under REMARKS, if necessary.

4.7.3.19 REF 15. ESTIMATED LANDING FUEL. Enter the estimated landing fuel weight and moment.

4.7.3.20 REF 16. ESTIMATED LANDING CONDITION. Calculate the Estimated Landing Weight and moment by subtracting the weight and moment for expendables and the weight and moment of TAKEOFF FUEL (REF 14) from the weight and moment at the TAKEOFF CONDITION (REF 12), and then adding the weight and moment from the ESTIMATED LANDING CONDITION (REF 15), respectively. Ensure the Estimated Landing Weight (REF 16) does not exceed the Maximum Landing Weight.

4.7.3.21 REF 17. ESTIMATED LANDING CG. Calculate, and enter the Estimated Landing CG using the weight and moment at the ESTIMATED LANDING CONDITION (REF 16).

4.7.3.22 Determine the Forward and Aft CG Limits at the ESTIMATED LANDING CONDITION (REF 16) by calculation or from the CG Limitations table in the aircraft Chart E (or CG Grid on the load adjuster). If the ESTIMATED LANDING CG (REF 17) is within the Landing CG Limits, enter the Forward and Aft CG Limits in the PERMISSIBLE CG LANDING blocks of the LIMITATIONS table.

4.7.3.23 If the weight of the ESTIMATED LANDING CONDITION (REF 16) and/or the ESTIMATED LANDING CG (REF 17) are not within permissible limits, additional changes in the amount or distribution of load and/or fuel are required, and a new Form F shall be completed.

4.7.3.24 MOST FORWARD & MOST AFT CG CALCULATIONS. In the blocks provided in the upper left-hand portion of the Form F, calculate the most forward and aft CG in flight, unless the CG is monitored during flight. The Chart E may indicate which loading conditions lead to the most forward and aft conditions during flight. Check the CG Limitations tables of the applicable Chart E, to ensure that the most forward and most aft CG are within the CG limits for flight.

4.7.3.25 When the most Forward CG condition and/or the most Aft CG condition does not remain within CG limits, additional changes in the amount or distribution of load and/or fuel are required, and a new Form F shall be completed.

4.7.3.26 REMARKS block. Enter pertinent information regarding mission-loading, takeoff, and/or landing conditions, as needed. Enter significant information that aircraft operators need to be aware of.

4.7.3.27 The following signatures are required as noted below. (Refer to Chapter 8 - Service Specific Requirements for signatures):

4.7.3.27.1 COMPUTED BY. The name and signature of the assigned Weight and Balance personnel who computed the form.

4.7.3.27.2 WEIGHT AND BALANCE AUTHORITY. The name and signature of the Weight and Balance Officer, Technician, Custodian, or Authority.

4.7.3.27.3 PILOT. The name and signature of the pilot shall appear on the ONE TIME USE Forms F submitted by the pilot or another crew member for flight clearance.

NOTE

The purpose of the pilot name is to indicate the Form F has been checked for currency and accuracy. In case of Forms F based on standardized loadings, the pilot indicates the final check of the form by inserting the appropriate Form F reference on the DD Form 175 (Military Flight Plan).

CHAPTER 5 WEIGHING AIRCRAFT

5.1 GENERAL. Aircraft weighings are required as outlined in Chapter 3, paragraph 3.9. Weighing with calibrated scales is the only sure method of obtaining an accurate Basic Weight and center of gravity (CG) location of an aircraft. When an aircraft is to be weighed, it should be in its Basic Weight configuration in order to ensure accurate results. Unless specified differently or in more detail in Chart E, this configuration shall be a "ready-for-flight" configuration with components required for flight installed (e.g. engines, blades), closed systems serviced to proper operating levels (e.g. hydraulics, transmission), and doors and windows closed. The aircraft shall be inventoried at the time of weighing for equipment actually in the aircraft.

5.2 WEIGHING EQUIPMENT. Aircraft weighing equipment shall be used to weigh aircraft only. Described below are three general types of aircraft weighing equipment.

5.2.1 Stationary Pit-Type Platform Scales. These scales are commonly flush floor installations, although some are used as surface-type portable scales. The flush floor installations generally are in a permanent location and the aircraft shall be taken to them. However, some flush floor scales have the capability to be removed from their installations when necessary and taken to the aircraft.

5.2.2 Portable Platform Aircraft Scales. This system consists of three or more platform scales with detachable ramps and wheel stops. Each platform is independent. Platforms can be arranged in various combinations to

provide for weighing aircraft of any size and landing gear configuration. The aircraft is positioned on the platform scales and the resulting weight forces are measured. Display of the measured value is either at each platform or is transmitted to a central display that collects values from all platforms connected to it. When values are collected at the central display, ensure that the values correspond with the location on the aircraft correctly (see Figure 5-1).

5.2.3 Electronic Weighing Kit. An electronic weighing kit (see Figure 5-2) contains load cells that measure one directional force applied to them. These load cells are inserted between aircraft jacks and jack points on the aircraft for weighing aircraft. Many kits have adapters so that the load cell will fit properly to the various types of jacks. The load cell shall be placed squarely and symmetrically on top of the jack head. Aircraft jack locations require constant monitoring to ensure that the jack is in a vertical alignment with the aircraft jack point, both longitudinally and laterally, in order to avoid injury to personnel, damage to aircraft or equipment, and to ensure accurate weighing results. Some weighing kits also come with two jack pad adapters, the use of which depends upon the shape of the jack. When the aircraft is raised using the jacks and is leveled, forces are measured by the load cells and transmitted electronically to a control panel. Care must be taken to ensure each measurement is attributed to the location on the aircraft correctly. Color-coding of cables and load cells is strongly recommended to help ensure that this happens. (See Figure 5-3).

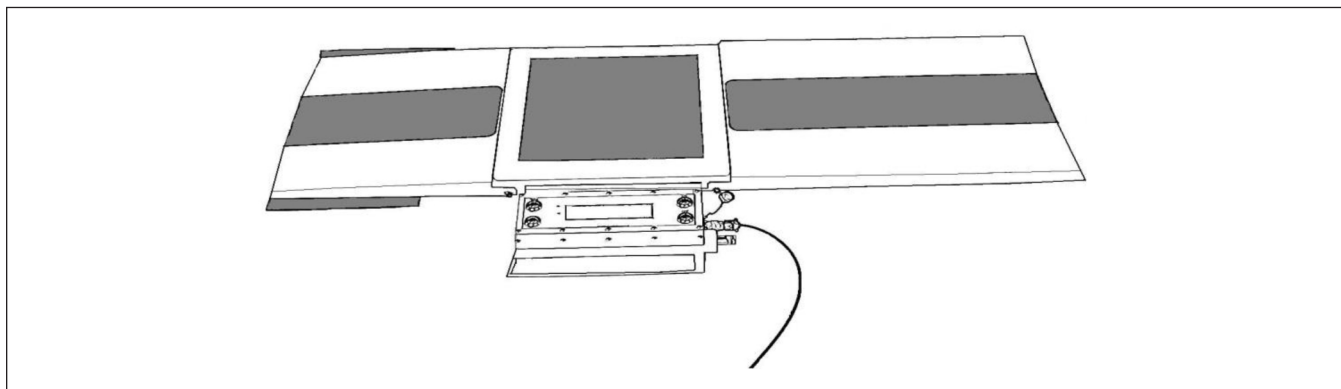

Figure 5-1. Typical Platform Scale Assembly

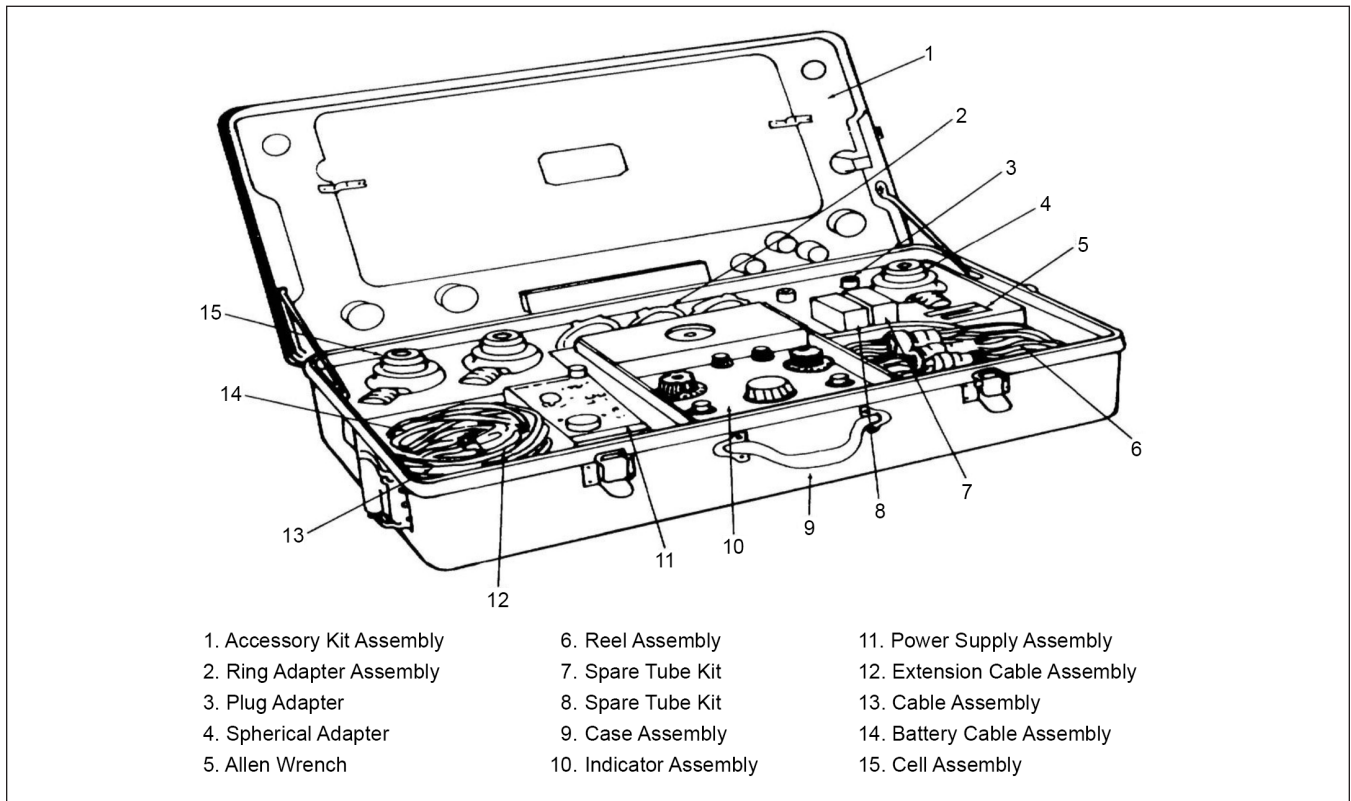

Figure 5-2. Electronic Weighing Kit (Typical)

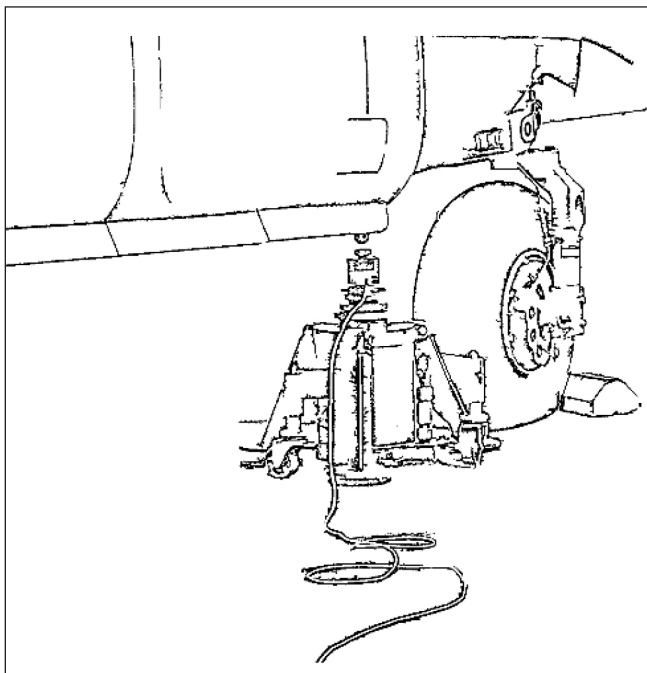

Figure 5-3. Load Cell and Jack

NOTE

Strict adherence to instructions for weighing equipment is necessary to ensure accurate results.

Refer to Chapter 8 - Service Specific Requirements for restrictions on the use of certain types of weighing equipment.

5.2.4 Calibration of Weighing Equipment. All custodians responsible for and technicians using weighing equipment are responsible for having equipment calibrated and certified by a government inspector of weights and measures or by commercial scale officials. Calibration shall be traceable to the National Institutes of Standard and Technology (NIST). Calibration procedures shall be those provided by the scale manufacturer or applicable service directives.

5.2.4.1 Scale and Load Cell Calibration. Standard calibration for aircraft scales and load cells is an accuracy of +/- 0.1% of the applied load unless otherwise determined by appropriate Service Engineering Organizations (see Chapter 8 for Service-specific Requirements).

5.2.4.2 Inclinometer Calibration. Inclinometers and digital protractors must be calibrated in accordance with manufacturer's instructions.

5.2.4.3 To check the accuracy of a spirit level, place the level on top of a clean, flat surface and note the position of the bubble. Turn the level 180 degrees and place it back on the surface in the same spot as before. The bubble should be in the same location for both readings. If not, adjust the level in accordance with manufacturer's instructions. If unable to adjust the level, use another spirit level that meets the accuracy check or another instrument.

5.3 WEIGHING ACCESSORIES. To measure data such as lengths, angles, and densities, weight and balance personnel require accessories such as levels, plumb bobs, measuring tapes, chalk lines and hydrometers. It may be necessary to prepare special devices for specific TMS/MDS that will be identified in the aircraft Chart E.

5.3.1 Spirit Level. At least one spirit level is required for leveling most aircraft. Two levels are recommended, one 24 inches long for spanning the distance between leveling lugs and another 6 inches long to use in places where sufficient space is not available for seating a 24-inch level. The levels should be a machinists' bench type of first-class quality with ground and graduate main vials and plain plumb vials. An inclinometer or digital protractor may be used in lieu of a spirit level on many aircraft.

5.3.2 Leveling Bars. Several leveling bars of varying lengths may be needed for spanning distances between leveling lugs of different aircraft. One set of bars usually comes with the weighing kit normally maintained by each authorized weighing facility. Some aircraft require special bars that will be identified in the respective Chart E.

5.3.3 Leveling Lugs. Points located on some aircraft to facilitate use of the spirit level in leveling aircraft.

5.3.4 Plumb Bobs. Plumb bobs are used to project points on the aircraft onto the floor for measuring dimensions in a level plane and for leveling some aircraft. Each plumb bob should have a slot in the head so that excess string, which could interfere with the free swing of the plumb bob, can be wound around the neck. Plumb bobs are normally included in the weighing kit.

5.3.5 Steel Tapes. A steel tape 600 inches in length and graduated in inches and tenths of inches is required. Since all weighing dimensions shall be read to one tenth of an inch, this type of tape eliminates the nuisance

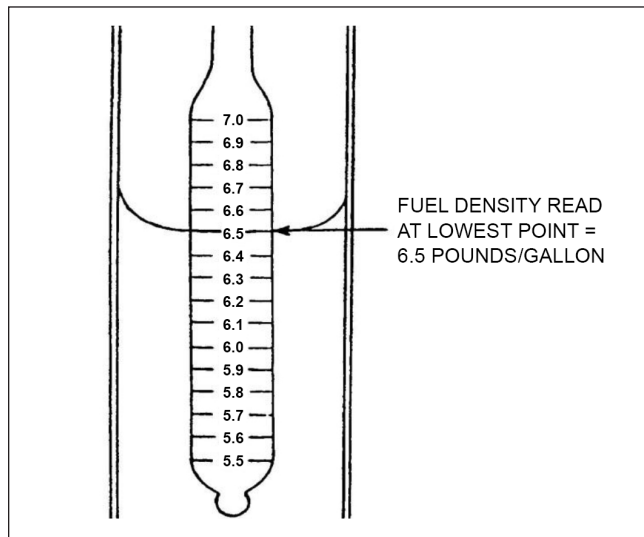

Figure 5-4. Reading a Hydrometer

and the possibility of errors associated with converting common fractions to decimals. A measuring tape, as described, must be included in the weighing kit.

5.3.6 Chalk Line. This is a string, covered with chalk, which is used to snap a straight line on the hangar floor between the vertical projections of reaction points or jig locations. The string should be sturdy and hard finished. The weighing kit usually includes a chalk line reel.

5.3.7 Hydrometers. A hydrometer with a calibration range from 5.5 to 7.0 pounds per US gallon should be used for determining the density of fuel when required. A transparent container for holding fuel samples and a pipette at least 12 inches long or some other similar device for withdrawing samples from the tank are necessary for use with the hydrometer. Care shall be taken not to damage the glassware. When determining the density of a fuel sample, the hydrometer should be carefully placed into the fluid within the transparent container. When reading the density, the hydrometer shall not touch the container and the reading should be taken at the lowest fuel point (See Figure 5-4).

5.3.8 Clinometer Or Inclinometer. An instrument used to measure the angle of incline or the attitude of the aircraft relative to the horizontal (level ground) is needed for those aircraft weighed in a non-level attitude. Angles shall be measured at locations specified in Chart E.

5.3.9 Thermometer. A thermometer calibrated in degrees Fahrenheit used to measure the temperature of the weighing site for scale calibration purposes. This item is not needed for scales with built-in temperature calibration.

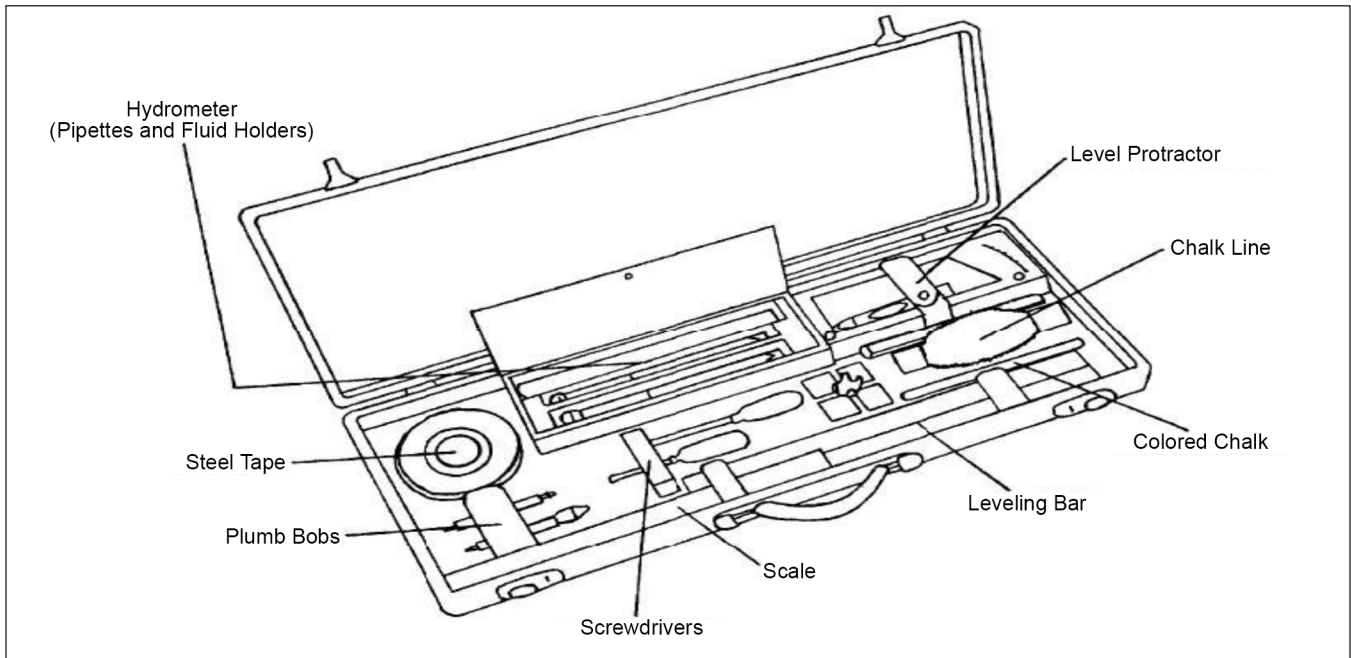

Figure 5-5. Accessory Weighing Kit

5.3.10 Accessory Weighing Kit. A kit containing compartments for each weighing accessory should be provided for storing and carrying the accessories (see Figure 5-5). This is a necessary precaution against loss or damage.

5.3.11 Aircraft Jacks. An approved type of jack may be required to raise the aircraft to a level position clear of the hangar floor. A good quality standard jack, with suitable capacity and extension range, should be used. The jack shall have an ample flat base area and have a suitable head, or adapter, to retain load cells and thus prevent slippage and resulting damage to the aircraft. The capacity of the jack points should also be checked to ensure the points would not be overloaded while weighing aircraft.

5.3.12 Jack Pad Adapters. A cylindrical-type adapter used to mate jack pads to a load cell assembly.

5.3.13 Jack Pads. Fittings attached to the aircraft structures which are used for reaction or jack points. A rounded or conical extension protrudes from the base of the jack pad and serves as the point of contact for the load cell assembly or aircraft jack.

5.4 WEIGHING PROCEDURES. A well-documented and orderly aircraft weighing procedure enables the ability to collect accurately measured weight and moment data in an efficient manner. It also lessens the chance of omitting steps necessary to collect required dimensions or scale readings. Refer to specific weighing instructions and/or procedures for specific aircraft type/design. The following is a general procedure to accomplish proper aircraft weighings if specific type/design procedures are not available:

NOTE

All resulting weight and balance data is suspect to be inaccurate if proper weighing procedures are not accurately performed during the weighing.

5.4.1 Preparation for Weighing Aircraft. The following describes the recommended procedure to prepare an aircraft for weighing:

- a. Thoroughly clean the aircraft inside and out, removing dirt and grease. If the aircraft is wet or moist from rain, dew or washing, the surfaces shall be allowed to completely dry before weighing.

CAUTION

Inspect areas for trapped water; drain and dry them as warranted.

b. Gather the required weighing equipment and ensure that all equipment is functional and in proper working order.

c. Drain the fuel tanks in accordance with the aircraft Chart E or other applicable instructions. All aircraft draining is normally done with the aircraft in level ground attitude.

NOTE

It is important that the fuel in the aircraft at the time of weighing duplicates the condition that has been established by the manufacturer's testing, which corresponds to the data provided in the aircraft Chart E.

Aircraft with foam in their tanks pose special problems. If aircraft with foam in the fuel tanks are not fully filled prior to draining, fill the tanks to capacity and then drain to a trapped fuel condition in order to duplicate the trapped fuel values. These aircraft always retain fuel in the foam; therefore, unless specific instructions are in the aircraft Chart E, draining should be terminated when fuel being drained starts to drip.

d. Operating Weight items and Payload items shall not be in the aircraft when it is weighed. These types of items are not listed as part of the Basic Weight on the Chart A and, therefore, should not be in the aircraft when it is weighed.

e. Check all reservoirs and tanks for liquids such as drinking and washing water, engine oil, hydraulic fluid, anti-icing fluid, cooling fluids, and liquid oxygen. Reservoirs and tanks should be empty or filled to normal capacity prior to weighing. Never weigh aircraft with partially filled reservoirs or tanks.

f. All waste tanks shall be empty.

g. Move the aircraft to the area where it will be weighed. To prevent side load or damage to equipment, do not set the aircraft brakes. Ensure aircraft control surfaces are in a static neutral position and that all doors,

canopies, rotor blades, folding wings/pylons, etc. are positioned in accordance with the Chart E. Inflate tires to normal pressure.

NOTE

Depending on the situation, a brake rider may be required to safely weigh and/or move an aircraft. Ensure that the brake rider does not apply the brakes at any time other than an emergency.

h. The aircraft shall be weighed in a closed hangar, or building, with no blowers or ventilating systems impinging on the aircraft. The slope of the floor shall not exceed 1/4 inch in one foot (1.2 degrees). Do not place scales on or over a crack, or drain in the floor. Jacks may straddle engineered expansion joints providing elevation does not change.

i. Conduct a Chart A inventory of equipment installed in the aircraft. This inventory shall be done under the supervision of the weight and balance technician responsible for the aircraft.

NOTE

A Basic Weight without the associated inventory is of no value.

j. Check the aircraft equipment against the Chart A and make corrections as necessary to accurately itemize all items of fixed operating equipment that will be included in the Basic Weight determined by weighing. The aircraft Chart A is absolutely necessary to properly accomplish this inventory. When the Chart A does not accompany the aircraft, it is the responsibility of the weight and balance supervisor or technician to prepare one before weighing.

k. Adjust the Chart C based upon the Chart A inventory if necessary.

l. Make an estimate of the "as-weighed" weight and moment condition by using the current Chart C Basic Weight and Moment and the data in Charts A and E. An example is shown in Figure 5-6. Items weighed but are not part of the current Basic Weight and Moment should be added to the current Basic Weight and Moment. Items not weighed but are part of the current Basic Weight and Moment should be subtracted from the current Basic Weight and Moment.

<u>ITEM</u>	<u>WEIGHT (lbs)</u>	<u>MOMENT (in-lbs/1000)</u>
Current Basic Weight and Moment (from Chart C)	24,916	10,842
Items that <u>will be</u> weighed but are <u>not</u> in Current Basic Weight and Moment:		
Weighing Equipment	176	82
Items that <u>will not</u> be weighed but <u>are</u> in Current Basic Weight and Moment:		
Decoder	-12	-5
Liquid Oxygen	-3	-1
Estimated "As Weighed" Weight and Moment	25,077	10,918
Balance Arm (C.G.)		435.4 in

Figure 5-6. Estimation of "As Weighed" Condition

5.4.2 Actual Weighing. The following describes the procedure to successfully complete an aircraft weighing. Refer to the aircraft Chart E and scale manufacturer's instructions for aircraft and scale specific instructions.

- a. Ensure that the Chart A inventory was completed as required in paragraph 5.4.1.i.
- b. Ensure all the scales are within their calibration date. If the scales are portable, set up the scales in accordance with the scale manual. Ensure battery operated scales are fully charged, or are plugged in.

CAUTION

Equipment damage may result from improper connection to power sources. Consult manufacturer's instructions for proper use of power sources. Do not connect external power if non-rechargeable batteries are installed.

- c. Warm up scales in accordance with manufacturer instructions (if required).
- d. Adjust scales for current location's altitude and latitude, if they are capable. If they are not, make manual adjustments in the CORRECTIONS block of the Form B. (See Appendix C for Corrections Block Table).

NOTE

Failure to adjust scales to current location's latitude and altitude may result in inaccurate weight measurements.

- e. Zero the scales.
- f. Position the aircraft onto the scales.

(1) Platforms. Do not use the aircraft brakes to stop the aircraft, because they may bind the scales and this would require re-zeroing of the scales. Ensure that the nose wheel (or tail wheel) is centered. Do not set the aircraft brakes because this may induce errors into the weighing. If necessary, put chocks in place but ensure that they are not in contact with tires.

(2) Load Cell on Top of Jack. Position the aircraft jacks with the load cell installed directly under the jack fittings. Ensure that the jacks and load cells are vertical by checking with a level or with the inclinometer and ensure that the jack/load cell combination is directly under the jack fitting on the aircraft both fore/aft and left/right.

NOTE

Exercise the scales/load cells prior to recording any measurement results. To exercise the scales, remove the aircraft from the scales/load cells and repeat steps 5.4.2.e and 5.4.2.f a minimum of two times. Reset the scales/load cells to zero if they do not zero themselves after load is removed from the scale/load cell.

- g. Aircraft Leveling. For most aircraft all weight and balance computations are based on measurements taken when the aircraft is in a level position. This position is achieved when the longitudinal and lateral axes of the aircraft are in a horizontal plane. Leveling aids have been installed in the aircraft by the manufacturer, and

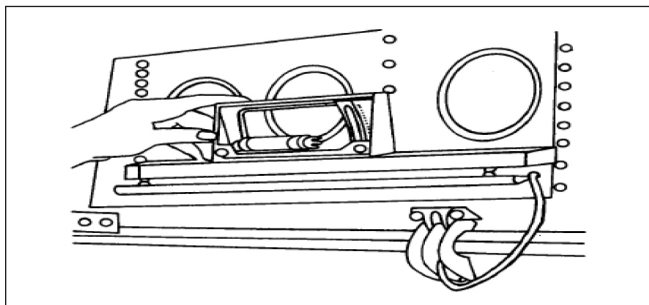

Figure 5-7. Leveling Lugs Inside the Aircraft

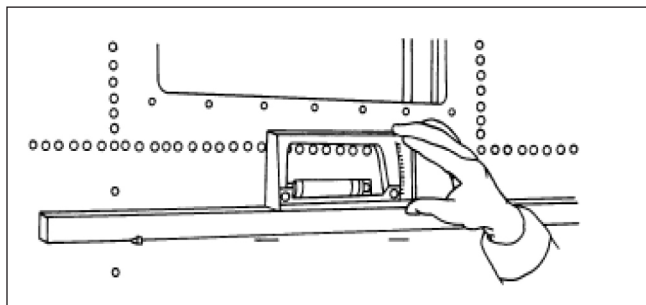

Figure 5-8. Leveling Lugs Outside the Aircraft

procedures have been developed to enable the aircraft to be positioned in a level attitude. Some aircraft use spirit levels to position the aircraft while other aircraft use plumb bobs in combination with leveling plates. See the Chart E for the particular aircraft being weighed for proper method and procedure.

NOTE

Some aircraft are weighed in a static, non-level position. Specific type/design weighing procedures contain instructions to correct for aircraft weighed in a non-level attitude. In this procedure, the angle the aircraft longitudinal axis makes to the horizontal plane is measured by either placing an inclinometer on the leveling bar or using a leveling plate provided in the aircraft by the manufacturer. See Chart E instructions.

(1) Spirit Levels, Inclinometer or Digital Protractor. Leveling lugs may be located on the inside or outside of the aircraft (see Figures 5-7 and 5-8). When the lugs are located inside the aircraft, it is often necessary for personnel observing the level to remain in the aircraft while it is being weighed to avoid disturbing its equilibrium. In this case, the weight and moment of the observer shall be subtracted from the total weight and moment by entering these values in Column I of the Form B. To use the leveling lugs, place the leveling bar squarely on the lugs. Then place the leveling device on the leveling bar. The aircraft shall be leveled both longitudinally and laterally.

(2) Plumb Bob. Another device provided for leveling of aircraft is a plumb bob (see Figure 5-9). The primary advantage of this type leveling over the spirit level type is that it is more accurate whenever the drop length is greater than the standard leveling lug span. To level an aircraft by using a plumb bob, suspend the plumb bob from the upper jig-located bracket and adjust the length

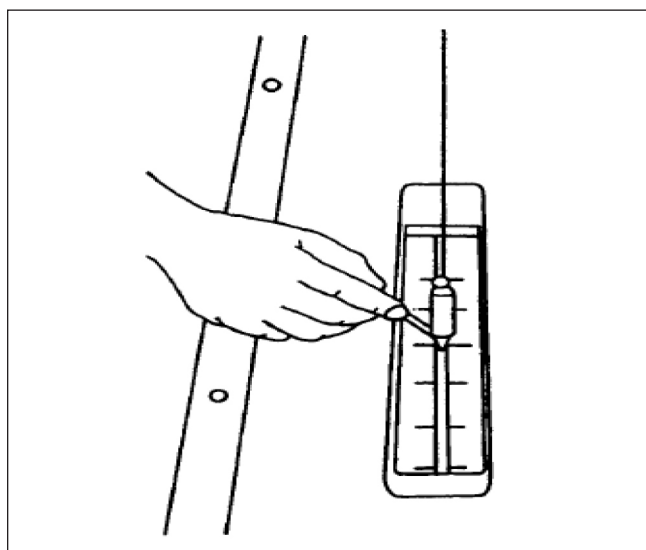

Figure 5-9. Plumb Bob

of the string to allow the plumb bob to swing very close to, but not touch, a graduated leveling plate. When the plumb bob is allowed to come to rest from swinging, the position of the plumb bob relative to the leveling plate indicates whether the aircraft is level or not. Raise or lower the nose and/or tail of the aircraft sufficiently to allow the plumb bob to be aligned with the leveling plate after the plumb bob is allowed to settle.

(a) Platform Leveling. Adjust the struts so that the point of the plumb bob is just above the intersection of the cross lines on the lower jig-located index plate. The aircraft will then be level laterally and longitudinally.

(b) Top-of-Jack Leveling. While carefully maintaining a level attitude laterally and longitudinally, jack the aircraft until all tires are clear of the ground. Aircraft on jacks are leveled by strategically raising and lowering jacks to establish a level attitude.

h. Read the scales and take measurements for required dimensions in accordance with proper weighing procedures. Record the readings and scale serial number at each reaction point. Remove aircraft from scale weighing surface, wait two minutes to allow the scale to return to a zero/tare state, and check for corrections. If scales do not return to zero, record as tare, and subtract or add to individual reactions' weight. Enter (if applicable) manual altitude and latitude scale corrections and enter in Corrections block.

NOTE

If scale does not return to zero and value is positive, enter the correction as a negative value on Form B. If scale does not return to zero and value is negative, enter the correction as a positive value on Form B.

NOTE

Record any reasons for corrections in the remarks section of Form B (e.g., "scales did not return to zero," or "brake-rider remained onboard for weighing.")

i. Dimensions Required for CG Measurement (Platform). Three dimensions shall be either measured or known to determine the longitudinal location of the as-weighed aircraft CG. The three dimensions are described as follows:

(1) The dimension from the reference datum to a known point (preferably a jig point). This known point is always listed on the aircraft diagram contained in the applicable Chart E.

(2) The dimension from the jig point to a chalk line drawn between the main reaction points.

(3) The dimension between the main and nose reactions or main and tail reaction points.

NOTE

If lateral and/or vertical CGs are required, see the aircraft specific manual for details.

j. Projection of Points to the Floor (Platform).

(1) Longitudinal (and lateral) dimensions are best determined by projecting reaction points to the hangar floor. Measurements between points will determine required dimensions for computing CG. When using platform or flush scales, these points must be marked on the hangar floor prior to removing the aircraft from the scales. It is recommended that masking tape be used on the hangar floor for marking these points. Chalk lines can be snapped between points and measurements can be made after removing the aircraft from the scales.

(a) Reference Point Projection. Suspend a plumb bob from the center of the jig point, keeping the plumb bob approximately 1/8 inch above the floor. Dampen out the swing of the plumb bob and make a cross mark on the masking tape directly under the tip of the plumb bob. Print the words "jig point" on the masking tape, near the cross, to distinguish it from the other reaction points.

(b) Main Reaction Projections. Suspend a plumb bob from the center of each main reaction point (i.e., each main wheel) to the masking tape as described above. It is necessary that a free fall be obtained for the plumb bob, so interference shall be avoided. It is also necessary that the plumb bob be dropped from the exact center of the reaction point (i.e. drop the plumb bob from the center of the axle of both left and right main reactions).

NOTE

Load Cells on Jacks do not use projection of points to the floor. The reaction points for the load cell top of jack locations are listed in the CHART E Loading Data.

(c) Nose or Tail Reaction Projections. The nose or tail reaction point is projected to the hangar floor in the same manner as described above. It is necessary that the plumb bob be dropped from the exact center of each reaction point (i.e., drop the plumb bob from the center of the axle both left and right of the wheel). The nose or tail wheel shall be centered prior to dropping the plumb bob. These projections are then marked on the floor with a small cross.

(d) When reference/jig point and all reactions have been confirmed to be accurately projected to the hangar floor and marked, have the aircraft removed from the area.

(e) Snap a chalk line between the two nose or tail reaction points. Taping down a string stretched between the two main reaction points can be used in lieu of a chalk line.

(f) Snap a chalk line or stretch a string between the two most outboard main reaction points. Repeat for each set of main gear fore/aft.

(g) Dimensions B and D shall be determined by measurement.

CAUTION

Do not use the values tabulated in Chart E. These are only approximate. Use of Chart E values can induce significant errors into the weighing results.

NOTE

The measurements may also be taken by placing the 10" mark of the tape at the desired point and subtracting 10" from the final tape reading. This technique may allow easier swinging of the tape and lead to greater accuracy.

k. Taking Measurements. All measurements should be taken with a steel tape. Two of the measurements are listed as "B" and "D" on the Form B - Aircraft Weighing Record. Dimension B is the perpendicular distance from projected jig point to the chalk line between the main reaction points. Dimension D is the distance from the chalk line between the main reactions to the nose or tail reaction point. When measuring these dimensions, the tape shall be parallel to the center line of the aircraft. These measurements shall be made accurately to a tenth of an inch or better to ensure accurate results of the computations which determine the as-weighed CG location of the aircraft. Measurements taken from the chalk line joining the main reaction points shall be measured perpendicular to the chalk line. These measurements may be determined quickly and accurately by placing the 10-inch mark of the tape on the desired point (the projection of the jig point or the projection of the nose (tail) reaction) and swinging the other end of the tape across the main reaction chalk line in a small arc. The shortest dimension read off the tape where the tape crosses the chalk line is the perpendicular distance from the point to the line. Care shall be taken to ensure the measuring tape is clear of any obstacles, and is taut, straight, and perpendicular to the line or string when taking measurements.

5.4.3 Recording Weight and Dimensions. All scale readings and dimensions should be recorded immediately on the Form B - Aircraft Weighing Record. Only dimensions B and D need to be measured. Distance I (from the reference datum to the jig point) is a fixed value obtained from the aircraft CHART E Loading Data. See type/design specific weighing instructions in Chart E or other documentation for dimensions to use when using the jack point weighing method.

5.5 VERIFICATION OF WEIGHING RESULTS.

5.5.1 Compute the difference between the calculated weight and arm (last entry on Chart C) and the actual Basic Aircraft Weight and Arm to be posted to Chart C (see Form B). If the weighing results are within the tolerances in Table 5-1, post the weighing to Chart C.

5.5.2 If the weighing results are outside of the tolerances in Table 5-1, accomplish the following:

5.5.3 Check calculations and measurements for errors.

5.5.4 Check scales for overdue calibration.

5.5.5 Check scales for correct altitude and latitude adjustments in accordance with the scale manufacturer's procedures.

5.5.6 Check slope of facility being used for weighing.

5.5.7 Check the accuracy of the level (spirit, inclinometer, or digital protractor).

5.5.8 Check and ensure that hangar doors are closed and that all fans and heaters are off.

5.5.9 Check the plumb bob for proper installation. i.e. String positioned in center of bracket V-notch. Does the plumb bob, digital protractor, or other leveling tool show required longitudinal and lateral angles/alignment?

5.5.10 Check aircraft (inside and out) to ensure that it is clean and completely dry.

5.5.11 Check to ensure chocks, flight gear, survival kits, fly-away gear, blade ropes, engine covers, and other non-Basic Weight items were removed.

5.5.12 Check that aircraft doors and panels were in proper configuration.

Table 5-1. Weighing Tolerances

Aircraft Basic Weight	Weight Tolerance (pounds)	Arm Tolerance	
		%MAC (Fixed-Wing)	Arm (Rotary-Wing)
≤ 75000 pounds	± Basic Weight x 0.4%	± 0.2%	± 0.2 inches
> 75000 pounds	± Basic Weight x 0.5%	± 0.5%	± 0.5 inches

5.5.13 Check fuel tank sump drains for lack of fuel flow making sure an appropriate container is in place in the event of fuel discharge.

5.5.14 If authorized to weigh with full fuel tanks, check fuel quantity and density if aircraft was not defueled. Aircraft must be fueled using the gravity open-port refueling method to ensure maximum usable fuel capacity is achieved. Do not use aircraft fuel quantity indicators to determine the quantity. Use the applicable operator's manual for usable fuel capacities.

5.5.15 Check Chart C for errors since the last weighing.

- a. Verify that Chart A updates have been properly reflected in Chart C.
- b. Verify that all aircraft modifications have been accounted for.
- c. Verify Chart A inventory matches the aircraft's weighing condition.

5.5.16 Ensure that any maintenance action taken place between when the aircraft was inventoried and when it was weighed has been accounted for.

5.5.17 If errors are found, make corrections and recheck if within tolerance in accordance with Table 5-1. If tolerance has been met, complete the Form B, and post the weighing to Chart C.

a. If no errors are found, or corrections did not bring results within tolerance in accordance with Table 5-1, repeat weighing procedures until TWO independent weighings and reaction measurements are within Repeatable Weighing Tolerance in the following paragraph.

b. Repeatable Weighing Tolerance. Weighings are repeatable if they are within 0.25% in weight and Arms are within 0.1% MAC for fixed-wing or within 0.1 inches

for rotary-wing. Individual weighings do not have to be consecutive. Once two repeatable weighings have been obtained, average the two, complete the Form B, and post the weighing to Chart C.

c. After posting weighing to Chart C, enter the following statement on Chart C: "In accordance with the Joint Service Technical Manual for Aircraft Weight and Balance, calculated vs. actual Basic Weight and Arm inspection completed with no errors found."

NOTE

When portable scales are being used and an error is suspected, rotating the scales is highly recommended in order to identify problems with individual scales as a possible source of error in the weighing results. Rotate the scales between the various reaction points (e.g., nose to left main, left main to right main, right main to nose) and reweigh the aircraft. Check for consistency of readings at each reaction point. If a discrepancy is noted, it is possible or likely that one (or more) of the scales is out of calibration or otherwise not operating properly. Rotate the scales once more (do not rotate back to the original position) and take a third reading. A scale that gives inconsistent readings relative to the others at the same reaction point should be replaced and the aircraft reweighed, or alternatively, the two consistent readings at each reaction should be taken, averaged and totaled and the result transferred to the Form B.

When using stationary beam balance pit scales, the beam balance may be "upset" in lieu of removing the aircraft from the scales.

5.5.18 Remove the aircraft from the scales.

5.5.19 Stow the equipment.

CHAPTER 6 WEIGHT AND BALANCE TOOLS

6.1 AUTOMATED WEIGHT AND BALANCE SYSTEM (AWBS).

6.1.1 General. AWBS may be authorized for maintenance of weight and balance records as directed by each Service Engineering Organization. (See Chapter 8 - Service Specific Requirements). Use of AWBS does not replace the user's knowledge of performing aircraft weight and balance nor does it alleviate the requirements of this manual for responsibility for accuracy of weight and balance data residing with the weight and balance authority. Ensure all calculations are correct and accurate.

a. AWBS is mandatory for some services, but not all. (See Chapter 8 - Service Specific Requirements).

b. Each service is responsible for certification of software that automates the weight and balance records. See Chapter 8 - Service Specific Requirements for guidance on how and when to obtain the latest authorized software for each respective service.

6.1.2 AWBS Forms and Charts are designed to be used in lieu of paper DD 365 forms. AWBS is one example of electronic forms.

6.1.3 For detailed instructions using AWBS, reference help resources in the software application itself.

6.1.4 Electronic signatures are authorized in lieu of normal pen or stamp signatures. When selected, AWBS provides a feature that enables Weight and Balance personnel to electronically sign Chart C and Forms F using public key infrastructure (PKI) credentials. (See Chapter 8 - Service Specific Requirements).

6.1.5 The AWBS Central Server is a web service designed to store AWBS aircraft records and to enable the transfer, upload/backup and download/restore aircraft files. When correctly configured and with proper permissions, AWBS users can upload aircraft records to and download aircraft records from the Central Server. The Central Server acts as a central repository or transfer hub for aircraft records between operational units. (See Chapter 8 - Service Specific Requirements).

6.1.6 Distribution of AWBS.

6.1.6.1 US military services provide specific ways to obtain the software. (See Chapter 8 - Service Specific Requirements).

6.1.6.2 For contractors, contact your Contracting Officer's Representative (COR) or Defense Contract Management Agency (DCMA) representative. For Foreign Military Sales, contact your Security Assistance Command.

6.2 OTHER WEIGHT AND BALANCE TOOLS.

6.2.1 Electronic Form F (i.e. Electronic Load Adjuster or Automated Form F (AFF) Generator).

6.2.1.1 Purpose. The requirements for digital methods that generate weight and balance data intended for use in completing the Form F for a specific aircraft type are defined below. The electronic Form F shall be developed to enable weight and balance personnel to (1) direct the load and (2) control the weight and CG of a particular aircraft type.

6.2.1.2 Authority for Use. All Electronic Forms F shall have the approval of the Service Engineering Organization that has responsibility for the baseline aircraft before it may be used. All program changes shall have prior approval before incorporation.

6.2.1.3 Objective. The objective of the Electronic Forms F is to replace the mechanical load adjuster and to eliminate the need to complete a paper DD Form 365-4 Form F.

6.2.1.4 Calculations. The design data upon which Electronic Forms F is developed shall be based upon the aircraft manuals.

6.2.1.5 Program Changes. The program shall be written to prohibit field changes to the approved and validated program. This will ensure uniformity and allow program control and verification. To the maximum extent possible, the program shall be designed to allow for future changes in the aircraft. For example, the original aircraft CG will change and new stores may be added to the list of items available for mission loading of the aircraft.

6.2.1.6 Ease of Operation. To the maximum extent possible, the program shall be designed for ease of use. Required keystrokes shall be minimized and required inputs shall be prompted by the program. Once the outputs have all been displayed, provisions will be made to redisplay them without repeating all of the user actions.

6.2.1.6.1 To facilitate ease of operations, the computer program should, to the maximum extent possible, follow the format of the Form F. Either the transport or tactical form shall be used as appropriate. Calculated values on the form such as Operating Weight and moment, and Total Aircraft Weight and moment shall be determined by the program. Subsequent changes to a value used in determining a calculated value shall result in the calculated value being automatically updated. For example, once an initial calculation has been made, updating the fuel weight will result in correction of the gross weight.

6.2.1.6.2 To the greatest extent possible, the computer shall not require input of standard items. Thus if the computer is designed for a single type/design aircraft, the normal index or moment of standard items such as crew, oil, stores, etc. will be used by the computer and will not be entered by the user. To further facilitate ease of use, the computer may use input items such as compartments or stations which the user may readily know and which the computer will convert to the appropriate arm. Once an item has been input, the program will check the input value against acceptable limits to verify its validity.

6.2.1.7 Computational Requirements. The Electronic Form F shall be designed to provide rapid operation for the following:

- a. Determination of the weight and CG location for any loading condition.
- b. Adjust the CG for any increase, decrease, or relocation of fuel, passengers, crew, stores, or any other load.
- c. Determine the required shift of fuel, passengers, crew or any other load item during flight operations to maintain the CG within the permissible limits.
- d. Determine the CG limitations throughout the allowable weight range. If the CG is affected by other factors like wing movement, these factors shall be taken into account.

e. Calculation of In-flight weight and CG for standard fuel usage to ascertain CG does not go outside of the CG envelope for a proposed mission.

f. All aircraft limitations shall be included such as floor loading, compartment capacities, pylon capacity, operational environments, and caution zones.

6.2.1.8 Accuracy. The Electronic Form F shall contain weights and arms of individual loading data within 0.1 pounds and 0.1 inches compared to values in the applicable manuals (e.g. Chart E, Flight Manual, and Loading Manual). The Electronic Form F shall compute the displayed Weights, CG, and Simplified Moments to the nearest tenth.

6.2.1.9 Instruction Book. An instruction book shall be developed for each weight and balance Electronic Form F. This book shall contain detailed instructions for operating the Electronic Form F. Solutions to sample problems shall be included along with appropriate illustrations to improve clarity and effectiveness. This instruction book shall be submitted to the Service Engineering Organization for approval prior to use with the Electronic Form F.

6.2.2 Manual Form F Loading Tools.

6.2.2.1 Load Adjusters.

6.2.2.1.1 Purpose. The purpose of the adjuster is to enable the pilot, crew chief, or loading personnel (1) to direct the load and (2) control the CG location of a particular model aircraft. A load adjuster enables accurate and rapid determination that aircraft CG is within an acceptable range for any given loading condition. Load adjusters determine the effects of any weight or location changes necessary to keep the CG within a safe loading range for items such as crew, fuel and cargo.

6.2.2.1.2 Description. There are two types of load adjusters. The more common slide-rule type (see Figure 6-1) and the circular type. All load adjusters operate on the principle of the addition and subtraction of moments for CHART E load items to and from the aircraft basic moment. This is done through the use of the index number scale.

6.2.2.2 See aircraft specific manuals for more details concerning Load Adjusters.

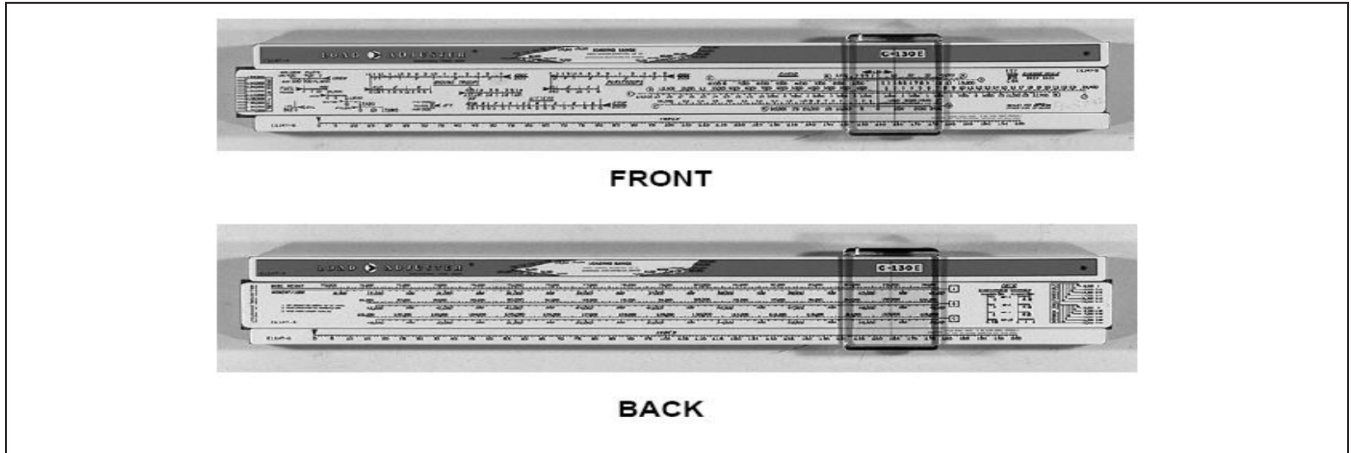

Figure 6-1. Load Adjuster

THIS PAGE LEFT INTENTIONALLY BLANK

CHAPTER 7 CENTER OF GRAVITY LOADING CALCULATIONS

7.1 GENERAL The purpose of this Chapter is to outline the method for determining the CG of a loaded aircraft. Location of the CG is very important to safety of flight because CG limits can be exceeded. The CG can be controlled by proper loading of the aircraft. The CG is the point about which an aircraft would balance if it were possible to support the aircraft at that point. It is the theoretical point at which the entire weight of an aircraft is concentrated. Balance, or the location of the aircraft's CG, is of primary importance to aircraft stability.

7.1.1 For most aircraft the prime concern is longitudinal balance, or the location of the CG along a designated reference line running from the nose to the tail. Location of the CG with reference to the lateral (side to side) axis is also important for some aircraft. If an aircraft will be flown in an asymmetrical configuration, it is required to calculate the lateral CG. The design of most aircraft is such that symmetry is assumed to exist about a vertical plane through the longitudinal axis. In other words, for each item of weight existing to the left of the fuselage centerline there is generally an equal weight existing at a corresponding location on the right. This lateral mass symmetry however may be easily upset due to unbalanced lateral loading. Location of the lateral CG is not only important from the aspect of loading rotary wing aircraft, but is also extremely important when considering fixed wing exterior drop loads. If required by aircraft-specific manuals (such as flight manual, loading manual, Chart E, etc.), the lateral CG shall be computed when a lateral imbalance is present or when flying in an asymmetric configuration (see Figure 7-1). The CG (henceforth, reference to CG will mean the longitudinal center of gravity) is not necessarily a fixed point; its location depends on the distribution of items loaded in the aircraft, and as variable load items are shifted or expended, there is a resultant shift in CG location. It should be realized that if the CG of an aircraft is displaced too far forward on the longitudinal axis a nose heavy condition will result. Conversely, if the CG is displaced too far aft on the longitudinal axis, a tail heavy condition will result. It is possible that an unfavorable location of the CG could produce such an unstable condition that the pilot could lose control of the aircraft.

7.1.2 Lateral and vertical CGs are not controlled on



Figure 7-1. Asymmetric Configurations

most aircraft, but are restricted to limits of operation on some aircraft. If required, the data and procedures necessary for lateral and/or vertical CG control are called out in the applicable aircraft specific manuals. Some aircraft may also track moments of inertia.

7.2 PRINCIPLES OF MOMENTS. A working knowledge of the principle of moments is necessary for understanding balance and for computing CG. For those unfamiliar with weight and balance terms, a moment is the product of a force or weight, times a distance. The distance used in calculating a moment is referred to as the arm or balance arm, and is usually expressed in inches. To calculate a moment, a force (or weight) and a distance must be known. (WAM: Weight x Arm = Moment) The distance is measured from a known reference point or reference datum to the point through which the force acts. A moment is meaningless unless the reference point is specified about which the moment was calculated.

7.2.1 For the purpose of illustration, an aircraft may be compared to a seesaw. Like the seesaw, in order for an aircraft to be in balance, or equilibrium, the sum of the moments on each side of the balance point must be equal in magnitude.

a. For example, referring to Figure 7-2, the moment produced about the fulcrum (reference point) by the 200 pound weight is 200 pounds x 50 inches = 10,000 inch-pounds counterclockwise.

b. The moment produced about the same reference point by the 100-pound weight is 100 pounds x 100 inches = 10,000 inch-pounds clockwise.

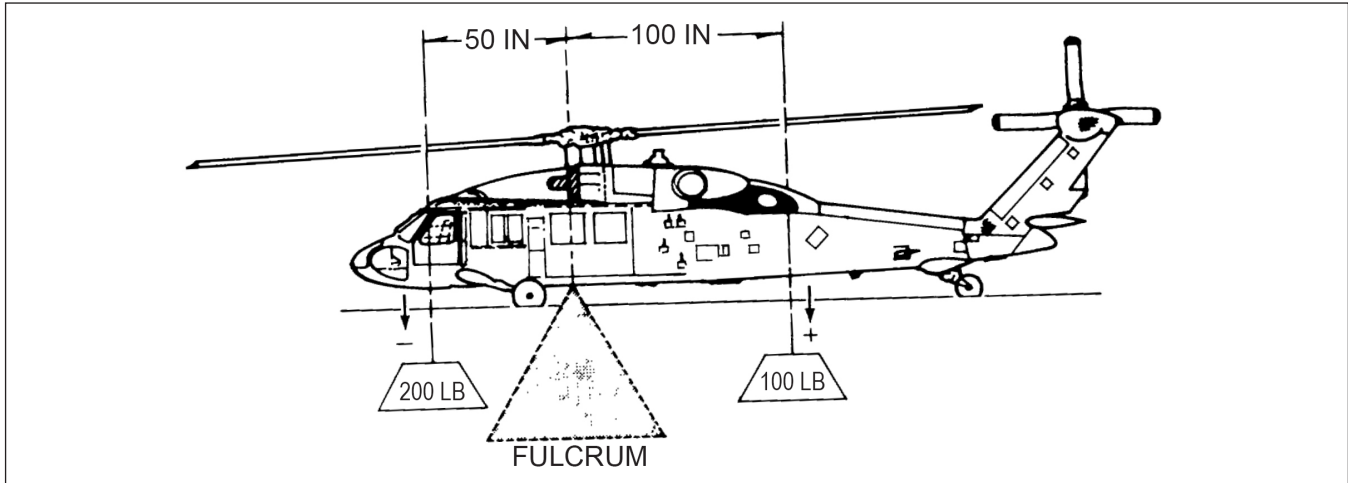

Figure 7-2. Aircraft Balance Point

c. In this case, the clockwise moment counterbalances the counterclockwise moment, and the system is in equilibrium. This example illustrates the principle of moments which is as follows: For a system to be in static equilibrium, the sum of the moments about a balance point equal zero.

7.2.2 As illustrated in Figure 7-2, the clockwise moment is arbitrarily given a positive (+) sign while the counterclockwise moment is given a negative (-) sign. Therefore, the sum of the moments about the fulcrum = +10,000 inch-pounds (clockwise) -10,000 inch-pounds (counterclockwise) which equals zero, and the system is in equilibrium. In determining balance of an aircraft, the fulcrum is the unknown, and the problem is one of determining the location of the fulcrum, or longitudinal center of gravity.

7.3 EFFECTS OF MOMENT ON AIRCRAFT CG. As in the case of the seesaw, which can be balanced about its fulcrum, an aircraft may be considered to be in balance about its CG. Loads placed forward of the aircraft CG can be balanced by placing loads aft of the CG. Loads located forward of the CG of an aircraft produce moments which tend to make the nose go down, whereas loads located aft of the CG produce moments which tend to make the tail go down. If any item is added forward of the CG or removed aft of the CG, a nose-heavy condition will result. Conversely, any item added aft of the CG or removed forward of the CG will produce a tail-heavy condition. It should also be realized that a moment can be changed without adding or removing a weight. Moments are changed, and therefore CG is changed, by simply shifting weight forward or aft.

7.4 DETERMINATION OF BALANCE CONDITION (LOCATION OF AIRCRAFT CENTER OF GRAVITY).

To determine the CG location of loaded aircraft, it is first necessary to obtain the Basic Weight and moment of the aircraft from Chart C. Add the weight of the items to be loaded to the aircraft Basic Weight to obtain the Gross Weight. Compute the moment of each load item by multiplying its weight by its arm. Find the Gross Weight moment by adding the basic aircraft moment and the moments of the load items. Determine the CG location by dividing the Gross Weight moment by the Gross Weight. Figure 7-3 illustrates the method for determining the CG location of a loaded aircraft.

7.4.1 In computations, any item of weight added to the aircraft is a plus weight. Any weight item removed is a minus weight. Balance arms are positive when measured aft of the reference datum. Balance arms are negative when measured forward of the reference datum. When multiplying weights by arms, the moment is positive if the signs are either both positive or both negative. Moments are negative if the signs of weight and arm are opposite. The following combinations are possible:

- a. Items added forward of the datum: (+) weight X (-) arm = (-) moment.
- b. Items added aft of the datum: (+) weight X (+) arm = (+) moment.
- c. Items removed forward of the datum: (-) weight X (-) arm = (+) moment.
- d. Items removed aft of the datum: (-) weight X (+) arm = (-) moment.

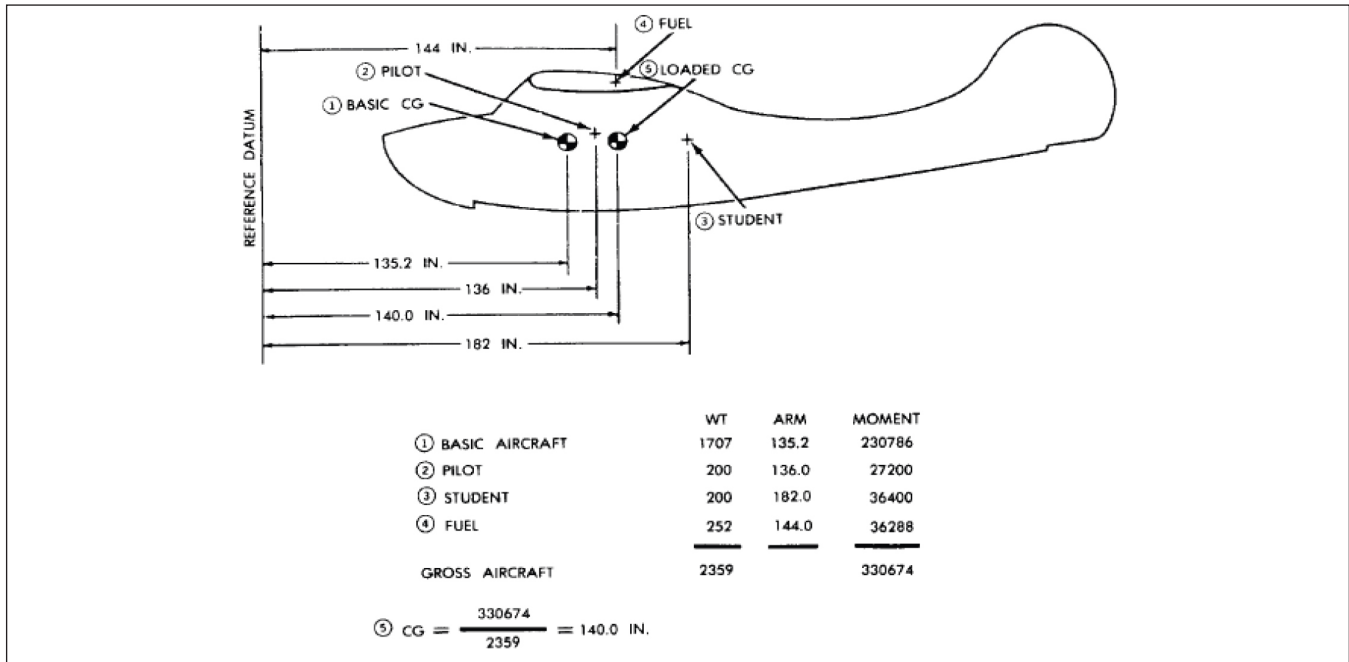

Figure 7-3. Calculating Aircraft Center of Gravity

7.5 EFFECTS OF UNBALANCED LOADING. When the aircraft is nose-heavy (CG too far forward), the pilot will experience difficulty in getting the nose up during landing. Other unfavorable conditions which may result are loss of aircraft maneuverability, overstress of the nose wheel structure in landing, and increase of pilot fatigue. When a tail-heavy condition exists (CG too far aft), the aircraft may become unstable. This condition increases pilot fatigue, and may lead to structural failure and spins.

7.6 DETERMINING CENTER OF GRAVITY FOR A GROUP OF ITEMS. It is sometimes desirable to find the average arm or CG for a group of objects in an aircraft. This is accomplished by finding the individual moment of each object in the group, adding these moments, and dividing this sum by the total weight of all the objects in the group. It is expressed by the formula:

$$\text{Average arm (in)} = \frac{\text{Total moment (inch pounds)}}{\text{Total weight (pounds)}}$$

It should be noted that basic aircraft weight and moment are excluded from this calculation. The total moment used in this formula must not be simplified.

7.7 CENTER OF GRAVITY LIMITS. All aircraft have allowable limits which the CG shall remain within for safe operations. After the CG of a loaded aircraft has been calculated, it is necessary to ensure that the CG falls within these allowable limits. These limits are specified in the applicable aircraft Chart E. If, after loading the aircraft, the CG does not fall within the allowable limits, it shall be necessary to shift loads.

7.7.1 The forward CG limit may vary with the Gross Weight of an aircraft. The forward CG limit is often restricted to control landing conditions. It may be possible for aircraft to maintain stable and safe for flight with the CG ahead of the forward limit as prescribed by landing conditions. However, since landing is one of the most critical phases of flight, the forward CG limit is restricted to avoid damage to the aircraft structure when landing, and to ensure that sufficient elevator deflection is available at minimum airspeed.

7.7.2 The aft CG limit is the furthest aft the CG is allowed. As the CG moves aft, the aircraft becomes less stable which reduces the ability of the aircraft to right itself after maneuvering or after disturbances by gusts. The allowable aft CG limit may also vary with the aircraft Gross Weight.

7.8 EXPRESSING CENTER OF GRAVITY. The CG is expressed in terms of inches from a defined reference datum, or alternatively, in percent Mean Aerodynamic Chord (% MAC) for fixed-wing aircraft.

7.9 LATERAL CG AND VERTICAL CG. Typical aircraft cannot be loaded beyond lateral or vertical CG limits. Aircraft that can be loaded asymmetrically, whether intentional or not, can possibly exceed lateral CG limits. Some aircraft require strict monitoring of the CG (and inertia) in all three axes; not just longitudinal. The principles in the next paragraph apply to lateral and vertical balance as well as longitudinal balance. If required, the data and procedures necessary for lateral and/or vertical CG control are called out in the applicable aircraft specific Chart E and/or manual.

7.10 MOST FORWARD AND MOST AFT CG CALCULATIONS. These calculations are designed to determine the most forward and most aft CG locations that could normally occur during the mission under consideration. Each computed CG should be carried to at least one decimal place and checked against the allowable limits. As the Gross Weight changes due to fuel use, expendable ammo, crew or passenger movement, and the release of expendable stores, the allowable CG limits may change. If the CG exceeds the limits, note it in the calculations but do not begin correction until all the CG calculations are completed. Then make the necessary corrections and run through CG calculations again to check the corrected condition. The following calculations deal specifically with Chart E data. The principles described also apply to calculations using a load adjuster; however, clearer calculating procedures for most forward and most aft CG calculations using load adjusters are included in Chapter 6 (Weight and Balance Tools).

7.10.1 Takeoff Gross Weight Condition. Prior to any mission CG calculations, a takeoff condition shall be determined. This is done by adding the various loading data weights and moment to the current Chart C Basic Weight and moment and computing the takeoff Gross Weight CG.

7.10.2 Landing Gear Retraction. Unless specifically stated in the Chart E, the takeoff condition is determined with the landing gear down. The raising of the landing gear causes an aircraft CG shift due to the moment change listed in the Chart E. If the Gear Up Moment Change (GUMC) is positive, raising the landing gear shifts the CG aft. As such, the gear-up condition is the aft CG condition and the gear-down condition is the forward CG condition. If the GUMC is negative, raising the landing gear shifts the CG forward. As such, the gear-up condition is the forward CG condition and the gear-down condition is the aft CG condition. In some cases, separate gear-up and gear-down CG envelopes are identified or provided. Ensure CG envelope matches gear position for calculations.

7.10.3 Fuel Use. Subtract from the forward and aft CG conditions the weight and moment for the usable fuel. The new weights and moments represent the forward and aft CG zero fuel conditions. Add to these conditions the partial fuel quantities (taken from the Chart E fuel tables) that cause the most forward and aft CG shifts. These quantities may not be explicitly called out, but need to be determined by trial and error. These calculations result in the forward and aft CG fuel use conditions. Compute the CGs.

NOTE

Determining the zero fuel CG is critical for determination of fuel loads that result in most-forward and most-aft CG conditions. The fuel load that causes the CG to shift furthest forward relative to the zero fuel CG is the fuel load that causes the most-forward CG condition. The fuel load that causes the CG to shift furthest aft relative to the zero fuel CG is the fuel load that causes the most-aft CG condition.

When fuel tables reflecting the effects of different aircraft attitudes (angles of attack) on the fuel CG are listed in the Chart E, these tables shall be evaluated along with the standard level flight fuel tables to determine the forward and aft CG fuel use conditions.

7.10.4 Expended Ammo. The CG movement caused by firing ammunition shall be considered. Subtract the weight and moment of the rounds carried from the two conditions derived in the previous paragraph and add the weight and moment of the retained ammo and cases, if any. Compute the new conditions CG and determine the direction of the CG shift. If the ammo used causes an aft shift when applied to the CG condition, the ammo used condition is the new aft CG condition. If the ammo used causes a forward CG shift when applied to the forward CG condition the ammo used condition is the new forward CG condition. If it causes a forward CG shift to the aft CG condition or an aft CG shift to the forward CG condition, the forward and aft conditions remain as before. If there is no apparent CG shift when applied to the forward (or aft) CG condition, then firing ammunition has no impact on forward and aft CG calculations.

7.10.5 Expending Stores. The calculations to determine the CG effect of the release of stores involves a number of computations covering each step of prescribed release sequence. If no sequence is prescribed for the mission, the sequences that cause the most forward and aft CG movement shall be determined and their effects calculated. The procedure is the same as described above for expended ammo.

7.10.6 Personnel Movement. In most cargo, transport, and similar aircraft, personnel (crew/troops/passengers) have the freedom to move about inside the aircraft at times during the flight. This movement can have considerable effect on the aircraft CG and should be evaluated. Included in the Chart E are tables that list moment changes resulting from the movement of standard weight personnel from one aircraft compartment to another. These moments are positive, or added, when the personnel movement is aft, while they are negative, or subtracted, when the movement is forward.

7.10.7 Corrections. Corrections shall be made if the calculated forward and/or aft CG falls outside the allowable CG limits. Some aircraft are equipped to carry variable ballast, which can be used to bring the CG within limits. In cargo, tanker, and transport aircraft, the CG can be shifted through the relocation of cargo, fuel and personnel. The use of alternate fuel and expendable stores sequences can also be used to negate some of the adverse effects of fuel use and store release. However,

whenever corrections are made, the mission calculations shall be modified and checked so that CG limits are not exceeded in other parts of the mission profile.

NOTE

Typically, a negative CG change is used to represent forward movement and a positive CG change is used to represent aft movement. A negative weight shift would result in removing weight.

7.10.8 Shift Equation. When the CG of a loaded aircraft does not lie within the prescribed limits, and certain load items can be moved about, the CG may possibly be corrected by shifting weight from one compartment or position to another. The following equation can be used to determine how much weight to shift how far:

$$(W_{SHIFT})(\Delta CG_{WS}) = (W_{TOTAL})(\Delta CG_{AC})$$

where:

$$W_{SHIFT} = \text{weight of shifted item (pounds)}$$

$$\Delta CG_{WS} = \text{distance that item is shifted (inches)}$$

$$W_{TOTAL} = \text{total weight of aircraft including the shifted item (pounds)}$$

$$\Delta CG_{AC} = \text{change in total aircraft CG due to shifted item (inches)}$$

a. To find how much weight needs to be shifted a known distance (ΔCG_{WS}) to attain the desired CG change (ΔCG_{AC}) (an example is shown in Figure 7-4):

$$W_{SHIFT} = \frac{(W_{TOTAL})(\Delta CG_{AC})}{\Delta CG_{WS}}$$

b. To find how far to shift a known weight (W_{SHIFT}) to attain the desired CG change (ΔCG_{AC}) (an example is shown in Figure 7-5):

$$\Delta CG_{WS} = \frac{(W_{TOTAL})(\Delta CG_{AC})}{W_{SHIFT}}$$

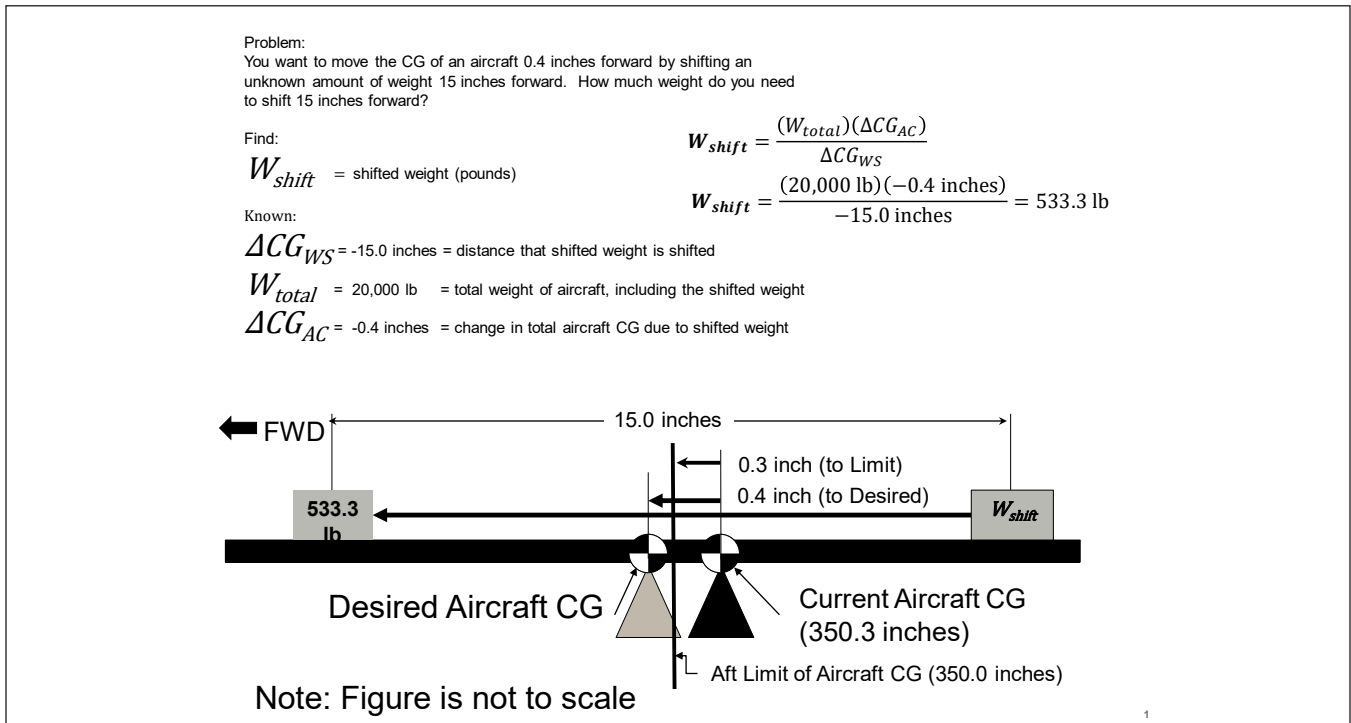

Figure 7-4. Example: Shift Unknown Weight a Known Distance To Achieve Desired Effect On Aircraft CG

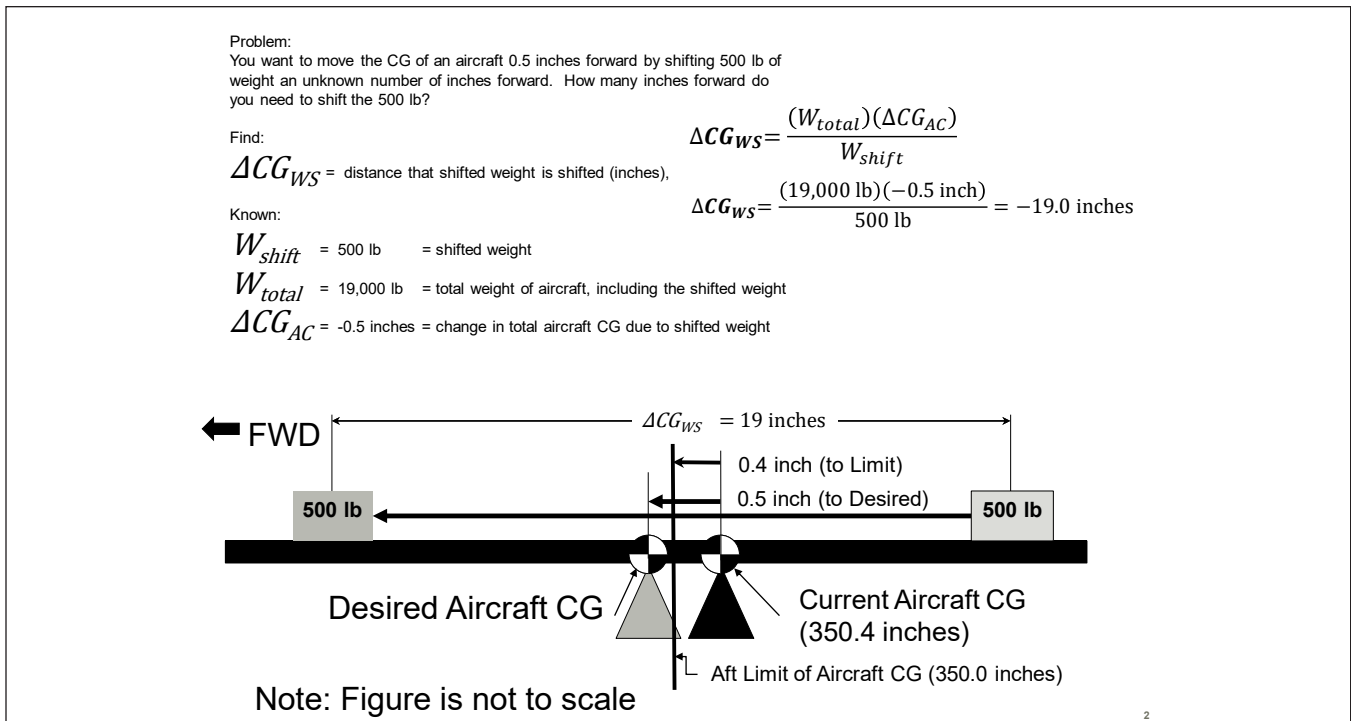

Figure 7-5. Example: Shift Known Weight an Unknown Distance To Achieve Desired Effect On Aircraft CG

7.10.9 Ballast Placement Equation. The following equation can be manipulated to determine the proper location for placement of temporary ballast:

$$(W_B)(CG_B - CG_D) = (W_G)(CG_D - CG_{GW})$$

where:

CG_B = CG of temporary ballast (inches)

W_G = aircraft weight excluding ballast (pounds)

W_B = ballast weight (pounds)

CG_D = desired aircraft CG with ballast (inches)

CG_{GW} = aircraft CG without ballast (inches)

a. To find the balance arm (CG_B) where temporary ballast (W_B) needs to be added in order to move the aircraft CG to a desired location (an example is shown in Figure 7-6):

$$CG_B = CG_D + \frac{(W_G)(CG_D - CG_{GW})}{W_B}$$

b. To find the amount of temporary ballast (W_B) that needs to be added at a known balance arm (CG_B) to move the aircraft CG to a desired location (an example is shown in Figure 7-7):

$$W_B = \frac{(W_G)(CG_D - CG_{GW})}{(CG_B - CG_D)}$$

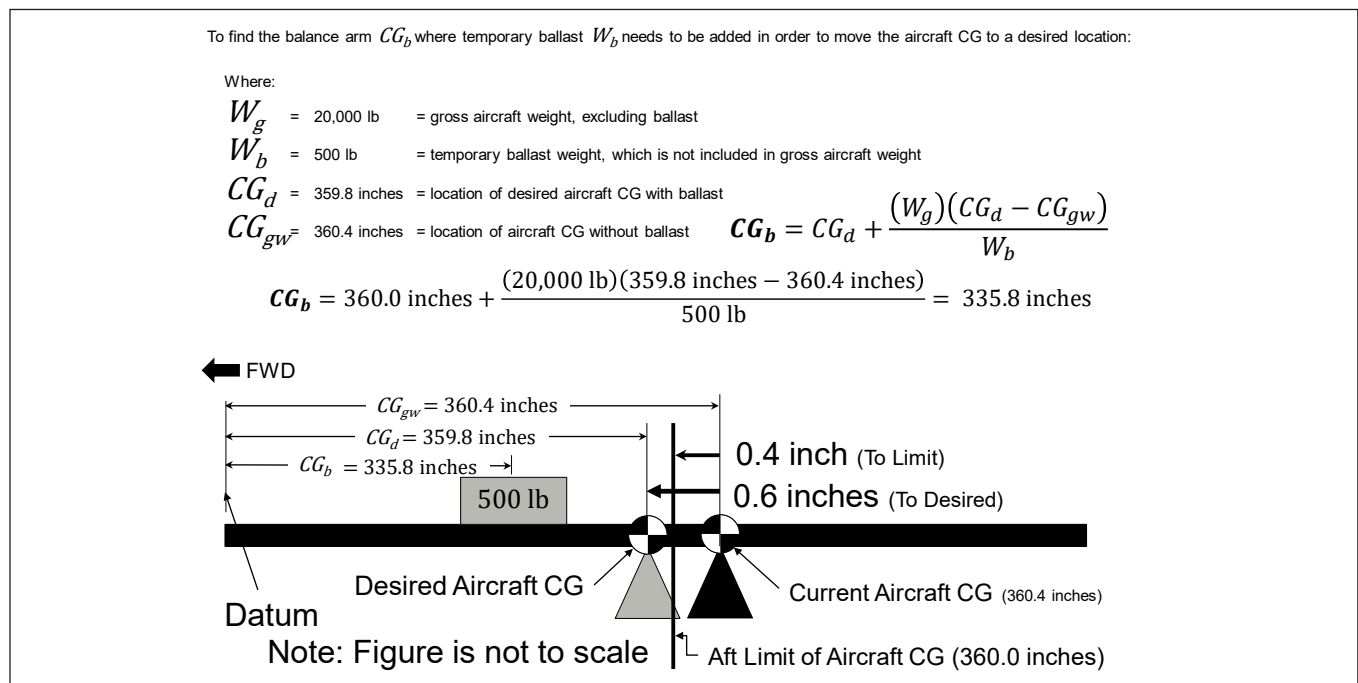

Figure 7-6. Example: Determine Required CG of Known Ballast Weight to Achieve Desired Effect on Aircraft CG

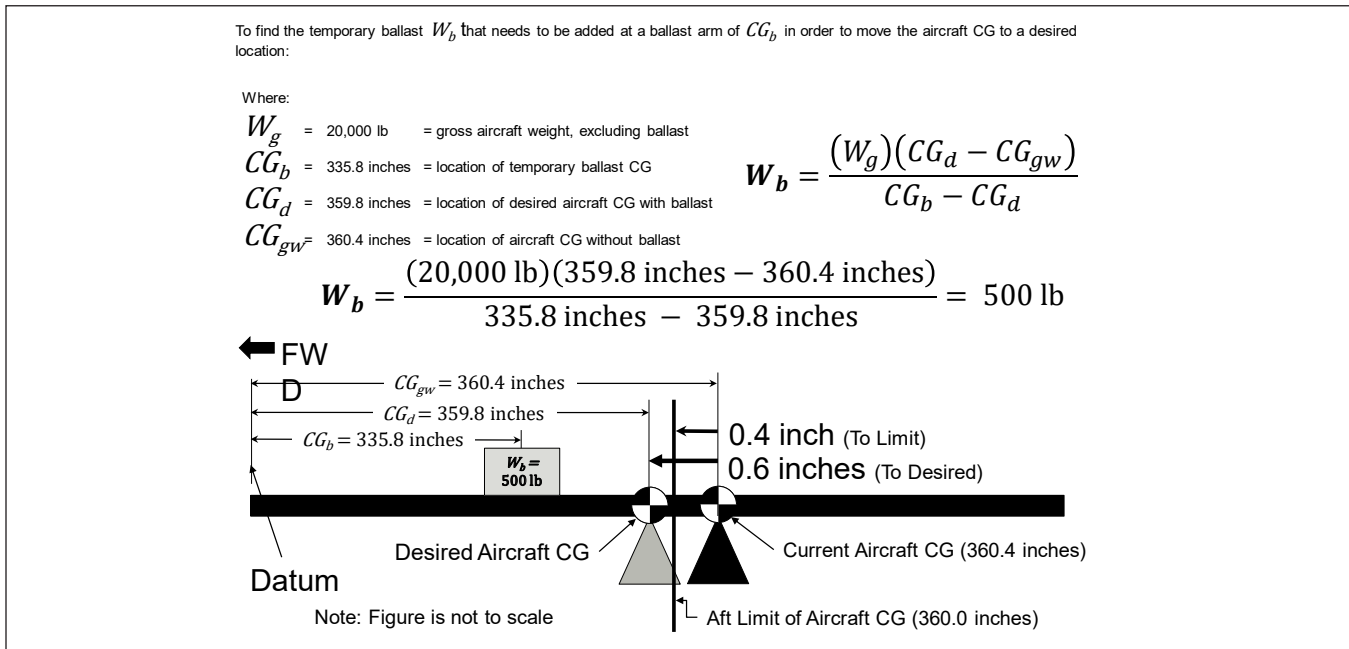

Figure 7-7. Example: Determine Required Ballast Weight at a Known CG to Achieve Desired Effect on Aircraft CG

7.11 SAMPLE. This sample deals with a FX-1 air superiority configured aircraft. It is armed with four AIM-13J missiles and full ammo, and also carries chaff and flares. The Basic Weight from the Chart C is 15,000 pounds with a moment of 50,000 inch-pounds/100. The forward CG limit is 20.0 percent MAC up to 20,000 pounds, and then increases linearly to 30.0 percent MAC at 40,000 pounds. The aft CG limit is constant at 50.0 percent MAC. The MAC and leading edge of the MAC (LEMAC) are 150.0 and 250.0 inches, respectively. Percent MAC is defined as:

$$\% \text{ MAC} = \frac{(\text{Balance Arm} - \text{LEMAC}) \times 100}{\text{MAC}}$$

7.11.1 The takeoff condition is derived as follows:

	Weight	Mom/100
BASIC WEIGHT	15,000	50,000
PLUS:		
Crew (1)	200	300
Ammo (retained)	100	325
Ammo (expendable)	150	400
Full Fuel	7,500	17,500
Adapter @ BL 150	50	200
Launcher @ BL 150	150	500
AIM-13 @ BL 200	350	1,000
AIM-13 @ BL 150	350	1,000
Chaff/Flares	25	100
TAKEOFF CONDITION	23,875	71,325
CG = (71,325 x 100) / 23,875	298.7 inches	

$$\% \text{ MAC} = \frac{(298.7 - 250.0) \times 100}{150.0} = 32.5 \% \text{ MAC}$$

7.11.2 The landing condition is defined as minus all expendable stores and with 1,000 pounds of fuel remaining:

	Weight	Mom/100
TAKEOFF CONDITION	23,875	71,325
MINUS:		
AIM-13 @ BL 150	-350	-1,000
AIM-13 @ BL 200	-350	-1,000
Ammo (expendable)	-150	-400
Full Fuel	-7,500	-17,500
PLUS:		
1,000 pounds Fuel	1,000	900
LANDING CONDITION	16,525	52,325
CG = (52,325 x 100) / 16,525	316.6 inches	

$$\% \text{ MAC} = \frac{(316.6 - 250.0) \times 100}{150.0} = 44.4 \% \text{ MAC}$$

7.11.3 The takeoff CG and landing CG are thus within the allowable limits.

7.11.4 The next step is to make the calculations described for the most forward and most aft center of gravity.

a. The landing gear retraction is defined in the Chart E as causing a minus 15,000 inch-pound moment change. Thus, the aft CG condition remains at the takeoff condition, while the forward CG condition becomes:

	<u>Weight</u>	<u>Mom/100</u>
TAKEOFF CONDITION	23,875	71,325
Landing Gear Retract		-150
FORWARD CG CONDITION	23,875	71,175
CG = (71,175 x 100) / 23,875	298.1 inches	

$$\% \text{ MAC} = \frac{(298.1 - 250.0)}{150.0} \times 100 = 32.1 \% \text{ MAC}$$

(1) The fuel condition that will produce the most aft CG shift is determined to be 2,000 pounds and 5,800 inch-pounds/100.

	<u>Weight</u>	<u>Mom/100</u>
AFT CG CONDITION	23,875	71,325
MINUS:		
Full Fuel	-7,500	-17,500
PLUS:		
2,000 pounds Fuel	2,000	5,800
NEW AFT CG CONDITION	18,375	59,625
CG = (59,625 x 100) / 18,375	324.5 inches	

$$\% \text{ MAC} = \frac{(324.5 - 250.0)}{150.0} \times 100 = 49.7 \% \text{ MAC}$$

The most forward CG shift is caused by 6,000 pounds of fuel and 15,000 inch-pounds/100 of fuel.

	<u>Weight</u>	<u>Mom/100</u>
FWD CG CONDITION	23,875	71,325
MINUS:		
Full Fuel	-7,500	-17,500
PLUS:		
6,000 pounds Fuel	6,000	15,000
NEW FWD CG CONDITION	22,375	68,825
CG = (68,825 x 100) / 22,375	307.6 inches	

$$\% \text{ MAC} = \frac{(307.6 - 250.0)}{150.0} \times 100 = 38.4 \% \text{ MAC}$$

b. The expendable ammo is located forward of the forward CG limits, so the forward CG condition remains with full ammo as in previous paragraph. The new aft CG condition is derived to reflect ammo used. (the FX-1 retains ammo cases)

	<u>Weight</u>	<u>Mom/100</u>
AFT CG CONDITION	18,375	59,625
MINUS:		
Ammo (expendable)	-150	-400
NEW AFT CG CONDITION	18,225	59,225
CG = (59,225 x 100) / 18,225	325.0 inches	

$$\% \text{ MAC} = \frac{(325.0 - 250.0)}{150.0} \times 100 = 50.0 \% \text{ MAC}$$

c. The four AIM-13 missiles are located aft of the aft CG limit, so their firing causes a forward CG shift. The new forward CG condition then becomes:

	<u>Weight</u>	<u>Mom/100</u>
FWD CG CONDITION	22,375	68,825
MINUS:		
AIM-13 (4)	-700	-2,000
NEW FWD CG CONDITION	21,675	66,825
CG = (66,825 x 100) / 21,675	308.3 inches	

$$\% \text{ MAC} = \frac{(308.3 - 250.0)}{150.0} \times 100 = 38.9 \% \text{ MAC}$$

The aft condition remains with the four missiles as before.

7.11.5 Thus, both the forward CG and aft CG are within the allowable limits. However, suppose the pilot weighed in at 150 pounds, instead of 200. That would mean a 50 pound weight reduction, and a 7,500 inch-pound moment reduction from what was calculated. With the pilot being forward of the MAC, the CG shift would be aft. The new aft CG condition would then be:

	<u>Weight</u>	<u>Mom/100</u>
AFT CG CONDITION	18,225	59,225
MINUS:		
Crew Weight Reduction	-50	-75
NEW AFT CG CONDITION	18,175	59,150
CG = (59,150 x 100) / 18,175	325.4 inches	

$$\% \text{ MAC} = \frac{(325.4 - 250.0)}{150.0} \times 100 = 50.3 \% \text{ MAC}$$

This is 0.3 percent MAC aft of the allowable aft CG limit. Thus, the calculations could have been performed and clearance given to the flight using the standard pilot weight, but because of the lighter weight pilot, the aircraft CG could have gone aft of the aft limit in flight.

7.12 CHART E LOADING DATA. The Chart E provides all the weight, arm, and moment data necessary to perform CG loading calculations. It is predominately in tabular form, listing the standard weights, arms, and moments of load items in such quantities and locations as are normally used.

NOTE

The weights listed in the Chart E are nominal values based on an average sample. Variability in weight for payload items is expected. Actual weights should be used whenever possible, especially when dealing with variable items such as the fuel (density varying with temperature) and the crew.

THIS PAGE LEFT INTENTIONALLY BLANK

CHAPTER 8
SERVICE SPECIFIC REQUIREMENTS

8.1 US ARMY REQUIREMENTS.

NOTE

Additional requirements may be provided in AR 95-1 and AR 95-20.

8.1.1 Related References.

- a. AR 95-1 Aviation Flight Regulations.
- b. AR 95-20 Contractor's Flight and Ground Operations.
- c. DA PAM 738-751 Functional User's Manual for the Army Maintenance Management System - Aviation (TAMMS-A).
- d. TB 43-180 Calibration and Repair Requirements for the Maintenance of Army Materiel.
- e. TB 750-25 Maintenance of Supplies and Equipment Army Test, Measurement, and Diagnostic Equipment (TMDE).
- f. TM 1-1500-328-23 Aeronautical Equipment Maintenance Management Policies and Procedures.

8.1.2 Weight and Balance Control. Operational aircraft weight and balance control shall be accomplished in accordance with the detailed requirements and instructions of the specific aircraft maintenance manuals, applicable regulations, and the requirements of this manual. In case of conflicting requirements, procedures, or instructions, US Army regulations and aircraft maintenance manuals shall take precedence over this manual.

NOTE

For some aircraft it may be possible to have a completely electronic Weight and Balance handbook if authorized by the appropriate Command and approved by the Weight and Balance Authority. However, a current backup (CD, Server, etc.) will be maintained at all times to prevent loss of data.

a. All weight and balance records will, as a minimum, be reviewed every 12 months. The last day of the month is the final day for completing the review. For example, if the previous review was completed on 8 April, the next review must be completed by 30 April of the following year. This review must include a weight and balance inventory of the aircraft and the following statement entered on the DD Form 365-3: "Calculated weight and moment per inventory completed at." The date and adjusted basic weight and moment will accompany this entry.

(1) DD Form 365, Record of Weight and Balance Personnel: Verify the last line entry indicates the person who is currently responsible for maintaining the aircraft's weight and balance handbook.

(2) DD Form 365-1, Chart A - Basic Weight Checklist Record: This review must include a Chart A inventory of the aircraft and the following statement entered on the Chart C: "Calculated Weight and Moment per inventory completed at (inventory location)".

(3) DD Form 365-2, Form B - Aircraft Weighing Record: Verify Basic Weight, Arm, and Moment match the last weighing on Chart C. Verify the associated inventory and weighing dates match.

(4) DD Form 365-3, Chart C - Basic Weight and Balance Record: Verify that all appropriate aircraft modifications entered on DA Forms 2408-5, 2408-5-1, and 2408-15 have been documented on the Chart C.

(5) DD Form 365-4, Weight and Balance Clearance Form F: Inspect all associated Forms F for accuracy of items listed, weights, and locations. Ensure forms reflect the appropriate configurations in which the aircraft may be operated, and that copies are located in the aircraft logbook.

(6) Upon satisfactory review of all weight and balance records and aircraft historical records, re-certify the records by entering on the Chart C the following statement. "Annual review of all weight and balance records completed at (inspection location)." The Basic Weight, Arm, and Moment will accompany this entry.

b. Temporary Equipment Changes. When equipment is installed, removed, or relocated within the aircraft for a period of less than 90 days, the weight and balance change(s) must be documented. If the cumulative temporary changes and Chart C changes not reflected on the Forms F result in a change of greater than or equal to +/- 0.3% in aircraft Basic Weight or 0.3 inches in aircraft Basic Arm, update or create new Forms F. Otherwise, document the change(s) by one of the following methods:

(1) Create new or update current Forms F.

(2) Make appropriate entries in aircraft maintenance records (DA Form 2408-13-1) containing a brief description, weight, arm, and moment of the changes.

c. Temporary Equipment Changes Exceeding 90 Days. When temporary changes entered in aircraft maintenance records exceed 90 days, enter a correction and sign off the DA Form 2408-13-1 entry after performing one of the following:

(1) For basic weight items, document the change(s) on the Chart A (if applicable) and Chart C. For load items, document change(s) on the Form F.

(2) Reinstall all items removed, remove all items installed, and relocate all items moved as part of the change(s).

8.1.3 Responsibilities.

a. Training Group. Refer to AR 95-1 and AR 95-20.

b. Sustainment Level Maintenance. N/A. Follow the instructions in paragraph 3.4.

c. Type Commander. Refer to AR 95-1 and AR 95-20.

8.1.4 Personnel Qualification Requirements. Refer to AR 95-1 and AR 95-20.

8.1.5 Forms and Records Disposition. Weight and balance forms are to be safeguarded and maintained with the same degree of importance as other records maintained for each aircraft.

a. The individual weight and balance forms serve various purposes. Therefore, the retention period of the forms will vary, as follows:

(1) The DD Form 365, Record of Weight and Balance Personnel is a semi-permanent form. It will be retained in the aircraft's weight and balance data file until space for additional entries has been exhausted and a new replacement form started. At the time, the replaced form may be destroyed locally.

(2) The DD Form 365-1, Chart A - Basic Weight Checklist Record (Chart A) and the DD Form 365-3 Chart C - Basic Weight and Balance Record (Chart C) are permanent forms. These forms will be retained in the aircraft's weight and balance data file for the life of the aircraft. As new forms are started because of exhausting entry space, the new forms will be stapled to the original form.

(3) The DD Form 365-2, Form B - Aircraft Weighing Record (Form B) is a semi-permanent form. The current completed form will be retained in the aircraft's weight and balance data file until the aircraft has been reweighed, a new form started, computations verified, and necessary entries made on the Form B. Upon completion of the above, the old Form B may be destroyed locally.

(4) The DD Form 365-4, Weight and Balance Clearance Form F (Form F) which has been used to compute standard loads, utilizing the aircraft's current Basic Weight, is considered a current work form as long as the load weights and locations remain current and until the Basic Weight has been recomputed/changed. A copy of the current form will be retained in the aircraft's weight and balance file until the entries require revision, at which time the old form will be destroyed locally or marked void.

(5) Chart E, Loading Data and Special Weighing Instructions. The Chart E is considered a semi-permanent chart and is to be retained in the aircraft's weight and balance file until a revised Chart E is published in the aircraft maintenance and operator's manuals. Following publication of the Chart E in these manuals, the Chart E in the aircraft file is no longer required and shall be removed and destroyed locally.

b. The weight and balance file shall be maintained and kept current for each aircraft from the time of delivery of an aircraft to the Army until salvage or retirement of the aircraft. Upon transfer of an aircraft, the commanding officer of the transferring activity is responsible for ensuring the weight and balance file accompanies the aircraft.

c. Any of the DD Form 365 series can be duplicated for reason of replacing lost, mutilated, or illegible forms. Duplication of lost or illegible forms requires a physical inventory for Chart A, weighing the aircraft, posting results to Chart C, and completion of Forms F.

d. The aircraft weight and balance file for aircraft stricken from the Army inventory is to be disposed of as follows:

(1) Destroyed/damaged aircraft. Destroy file locally, after necessary investigation and reporting, provided the aircraft does not fall into any of the following categories:

(a) Weight and balance records of aircraft that have been involved in accidents resulting in death or injury to any person, and/or damage to other than Government property that is classified as combat loss IAW AR 385-40, paragraph 2-5 are to be disposed of IAW Final Disposition Instructions issued by AMCOM, AMSAM-MMC-MA-OS. If the loss is not classified as combat loss IAW AR 385-40 paragraph 2-5, the weight and balance records are to be stored and secured with the wreckage and treated as legal evidence IAW DA Pam 27-162. The period of retention is variable. Final Disposition Instructions will not be issued from AMCOM, until a letter of release is issued by controlling Staff Judge Advocate (SJA), with AMCOM legal review and concurrence.

(b) Damaged aircraft which are uneconomically repairable (by Army standards), under disposal conditions, may be transferred or offered for sale to other than an Army custodian. The weight and balance file for such aircraft shall accompany the aircraft to the acquiring agency/individual(s).

(c) Excess aircraft. For aircraft whether in a serviceable or repairable condition which are to be transferred or offered for sale to other than Army custody, the weight and balance file will accompany the aircraft to the acquiring agency/individual(s).

8.1.6. Aircraft Classifications. Manned and unmanned aircraft weight and balance classifications are stated in the appropriate operator's manual. All aircraft where weight and balance class is not stated in the operator's manual shall be considered Class 2. For manned aircraft, Class 1 and Class 1B are equal.

8.1.7 Form F.

a. Procedures. Use current aircraft operator's manual and applicable Airworthiness Releases (AWRs) to complete and maintain Forms F.

b. All assigned Forms F shall be reviewed for accuracy every 90 days. The inspection due date window shall follow TM 1-1500-328-23 requirements for Recurring Special Inspections.

c. For test/developmental equipment installations/removals, entries may be recorded on the Form F for the duration of the test/development.

d. Use of Forms F - Transport versus Tactical: Aircraft designed to transport personnel shall use the Transport Form F; those aircraft not designed to transport personnel, shall utilize the Tactical Form F regardless of the operating environment.

NOTE

When aircraft are operated at critical gross weights or near CG limits, the actual weight and location of each individual occupant, equipment, and all load items will be used.

e. Entry of Taxi Fuel is not necessary unless required to bring aircraft into safe CG and/or weight range.

f. Weight and Balance Authority Signature Block. Enter signature, electronic signature, or technical inspector stamp of the person assigned to aircraft IAW DD Form 365.

NOTE

Local Commander may establish policies and procedures allowing deviation from the weight and balance authority signature.

g. Standardized Loading (CANNED Form F). N/A.

h. Transport Form F. The following Warning, Cautions, and Notes apply to the Transport Form F.

WARNING

Verify on-board flight performance system (e.g. Perf Page, FMS, CAAS) Basic Weight and Moment/Simplified matches Reference 1 of the current record DD Form 365-4, Weight and Balance Clearance Form F.

CAUTION

Fixed-wing aircraft need to be aware of potential CG shifts during flight due to Gear Up Moment Changes (GUMC), movement of personnel, expenditures of cargo, ordnance, and armaments. Special care is required for computing Takeoff CG (Gear Up) and Landing CG (Gear Up) to mathematically represent the entire flight from takeoff to landing.

NOTE

Aircraft with non-retractable landing gear should use/verify the following limitations: Takeoff Weight Limit, Landing Weight Limit, Takeoff CG (Gear Down), and Landing CG (Gear Down). Aircraft with retractable landing gear should also use/verify Ramp Weight Limit (if applicable), Takeoff CG (Gear Up) and Landing CG (Gear Up). Zero Fuel WT and CG limits may require computing IAW the aircraft operator's manual.

i. Tactical Form F. The following Warning, Cautions, and Notes apply to the Tactical Form F.

CAUTION

Fixed-wing aircraft need to be aware of potential CG shifts during flight due to Gear Up Moment Changes (GUMC), expenditures of cargo, ordnance, and armaments. Special care is required for computing Takeoff CG (Gear Up) and landing CG (Gear Up) to mathematically represent the entire flight from takeoff to landing.

NOTE

Rotary-wing aircraft with non-retractable landing gear should use/verify the following limitations: Takeoff Weight Limit, Landing Weight Limit, Takeoff CG (Gear Down), and Landing Gear CG (Gear Down).

NOTE

Fixed-wing and rotary-wing aircraft with retractable landing gear should also use/verify Ramp Weight Limit, Takeoff CG (Gear Up) and Landing CG (Gear Up). Zero Fuel WT and CG limits may require computing IAW the aircraft operator's manual.

8.1.8 Aircraft Weighings.

a. Aircraft Weighing Requirements.

(1) Each aircraft will be weighed IAW this technical manual's Section 3 and when the period since the previous weighing reaches 36 months for a Class 1 aircraft and 24 months for a Class 2 aircraft. The date due reweigh window shall follow TM 1-1500-328-23 requirements for Recurring Special Inspections.

(2) Each aircraft will be weighed when Overhaul or Major airframe repairs are accomplished. For example, the following actions constitute a major overhaul: extensive airframe repairs, RESET, tail boom replacement, etc.

(3) Alternate Weighing Methods. Contact Service Engineering Organization POCs listed in paragraph 8.1.8d(1).

b. Other Authorized Weighing Facility. N/A.

c. Combat Aircraft Weight and Balance Management.

(1) Special circumstances exist in deployed locations which prevent ideal conditions for weighing. For those aircraft deployed within the theater of operations, weighing of aircraft is permitted in an open hangar if the following conditions are met:

(2) There is no risk of aircraft falling off jacks (if used) due to air movement.

(3) Scale readings do not change for a minimum of 30 seconds prior to recording the weight.

d. Weighing Deferments. 90-day combat weighing deferment.

(1) The unit commander (or designate representative) may request a 90-day weighing deferment

when operating in a combat theater. Send request with brief explanation why the aircraft cannot be weighed along with the copy of the aircraft's weight and balance file to the supporting Liaison Engineer (LE). If LE is not available, send request to the following address or email address:

DIR, CCDC AvMC
 ATTN: (POCs Office Symbol, Contact Name,
 See (a)-(g) below)
 4488 Martin Road
 Redstone Arsenal, AL 35898-5000

(a) AH-64: FCDD-AMA-D,

Email: usarmy.redstone.ccdc-avmc.mbx.ama-d-tts@mail.mil

CC: usarmy.redstone.ccdc-avmc.mbx.ama-a-tts@mail.mil

(b) UH-60: FCDD-AMA-U,

Email: usarmy.redstone.ccdc-avmc.mbx.ama-u-tts@mail.mil

CC: usarmy.redstone.ccdc-avmc.mbx.ama-a-tts@mail.mil

(c) CH-47: FCDD-AMA-C,

Email: usarmy.redstone.peo-avn.list.cargo-ae-c-tts@mail.mil

CC: usarmy.redstone.ccdc-avmc.mbx.ama-a-tts@mail.mil

(d) Fixed Wing: FCDD-AMA-B,

Email: usarmy.redstone.ccdc-avmc.mbx.ama-b-tts@mail.mil

CC: usarmy.redstone.ccdc-avmc.mbx.ama-a-tts@mail.mil

(e) Special Operations Aircraft:

FCDD-AMA-T,

Email: usarmy.redstone.ccdc-avmc.mbx.ama-t-tts@mail.mil

CC: usarmy.redstone.ccdc-avmc.mbx.ama-a-tts@mail.mil

(f) Unmanned Aircraft Systems:

FCDD-AMA-V,

Email: usarmy.redstone.ccdc-avmc.mbx.ama-v-tts@mail.mil

CC: usarmy.redstone.ccdc-avmc.mbx.ama-a-tts@mail.mil

e. Aircraft Weighing Area.

(1) When floor slope is questionable, contact supporting Department of Public Works (DPW) or servicing agency for hangar floor survey. For a field expedient method, contact supporting unit Logistics Assistance Representative (LAR).

f. Aircraft Fuel System.

(1) Prepare aircraft fuel tanks in accordance with applicable maintenance manuals (alternate source is Chart E instructions). Weighing aircraft with full fuel tanks is not recommended and in some instances not authorized.

(2) Unusable and trapped fuel shall be listed on the Chart A as separate entries.

(3) If the aircraft is weighed with drained fuel tanks, unusable fuel listed on the Chart A will reflect "IN A/C" and the data also entered on the Form B, Column II.

(4) If the aircraft is weighed with a totally dry fuel system(s), unusable and trapped fuel listed on the Chart A will reflect "IN A/C" and the data also entered on the Form B, Column II.

(5) If the aircraft is weighed with full fuel tanks, fill the tank(s) to capacity using the gravity open-port method. The weight of usable fuel must be entered under Column I on the Form B. Usable fuel is not part of Basic Weight. Never weigh an aircraft with partially filled fuel tanks.

(6) Allow sufficient time for fuel temperature and movement to stabilize after refueling and aircraft positioning for weighing. When determining the density of a fuel sample, the hydrometer should be carefully placed into the fluid within the transparent container. When reading the density, the hydrometer must not touch the container. Float hydrometer in a sample of fuel from each tank just prior to weighing and record the weight per gallon; read this value at the lowest point of the meniscus (see Figure 5-4).

g. The following actions must be performed prior to aircraft weighing (in addition to this joint manual and aircraft specific requirements).

(1) Review aircraft logbook forms and records (DA Form 2408-13-1 and DA Form 2408-14-1) to ensure all aircraft parts/items are installed prior to weighing.

(2) Review aircraft historical forms and records (DA Form 2408-5 and DA Form 2408-5-1) and the Chart C to ensure all applied modifications has been properly documented on all appropriate forms and records.

h. The Weight and Balance Technician/Custodian assigned to the aircraft IAW the DD Form 365 shall ensure that all required parts/items are installed on the aircraft prior to record weighing.

8.1.9 Transfer and Acceptance of Aircraft. Both are required.

a. The weight and balance authority will transfer when one or more of the following occur:

(1) Aircraft is transferred/received to a new organization.

(2) Work ordered to next level maintenance which results in the weight and balance records requiring updates. An update constitutes any entries made to the Chart C.

b. The Chart A inventory shall be performed whenever:

(1) The aircraft is transferred to a new unit with a change of weight and balance authority.

(2) The Weight and Balance Technician receiving the aircraft shall perform a Chart A inventory of the aircraft to ensure the delivery condition or assumed operating condition recorded by the manufacture in Charts A and C matches the actual operating condition to be used by the custodian. If not, the necessary adjustments shall be made.

(3) The pilot reports unsatisfactory flight characteristics with weight and/or balance implications.

(4) The aircraft is weighed.

(5) At time intervals required by regulation.

8.1.10 Scales.

a. Scale Calibration. Commanders of Army organizations which operate, maintain, or modify aircraft are responsible for ensuring that weighing equipment under their jurisdiction are calibrated periodically and certified by a government inspector of weights and measures or by commercial scale officials in accordance with TB 750-25 and TB 43-180. Unless directed in these TBs, scales shall be calibrated or certified correct at least once every 12 months.

b. Scale Accuracy. For deviation from the scale accuracy requirement contact the LE or POCs listed in paragraph 8.1.8d(1).

8.1.11 Unmanned Aircraft System (UAS). Refer to AR 95-1.

8.1.12 Weight and Balance Guidance For Aircraft Modifications.

a. The following instructions are intended to serve as a standard for aircraft modifications with regards to weight and balance management.

b. Typically, A-Kit items are listed exclusively on Chart C, with B-Kits listed on Chart A and posted to the Chart C.

c. Weights, Arms, and Moments shall be listed to at least one decimal place. It is recommended to use one decimal place, per Figures 8-1 - 8-3. Moments are simplified by a constant per MDS (/100, 1000, etc.).

Chart A				
(Items that are removed are listed below)				
ITEM NO.	ITEM DESCRIPTION	WEIGHT	ARM	MOM/1000
B-XXX	RADIO, FM #1 12345-A	2.3	233.0	0.5
F-XXX	SIGNAL CONDITIONER, LH ABC-123	3.5	515.0	1.8
F-XXX	SIGNAL CONDITIONER, RH ABC-123	3.5	515.0	1.8

Chart A				
(Items that are installed are listed below)				
ITEM NO.	ITEM DESCRIPTION	WEIGHT	ARM	MOM/1000
B-XXX	RADIO, MULTIBAND 5678-B	1.6	225.0	0.4
F-XXX	MULTIBAND SIGNAL COND., LH 129-S	3.5	496.4	1.7
F-XXX	MULTIBAND SIGNAL COND., RH 129-S	3.5	496.4	1.7

Figure 8-1. Chart A Aircraft Modification Example

Chart C					
Make entries for items removed/added as shown below.					
Ensure a Header and Footer that reflect the MWO are added to the Chart C.					
ITEM NO.	IN/OUT	ITEM DESCRIPTION	WEIGHT	ARM	MOM/1000
	Header	Beginning of MWO 49-1979-391 Multiband Radio			
B-XXX	Out	RADIO, FM #1 12345-A	2.3	233.0	0.5
F-XXX	Out	SIGNAL CONDITIONER, LH ABC-123	3.5	515.0	1.8
F-XXX	Out	SIGNAL CONDITIONER, RH ABC-123	3.5	515.0	1.8
	Out	Wiring and Associated Hardware	0.8	179.0	0.1
	In	Wiring with Hardware	10.4	209.6	2.2
B-XXX	In	RADIO, MULTIBAND 5678-B	1.6	225.0	0.4
F-XXX	In	MULTIBAND SIGNAL COND., LH 129-S	3.5	496.4	1.7
F-XXX	In	MULTIBAND SIGNAL COND., RH 129-S	3.5	496.4	1.7
	Header	End of MWO 49-1979-391 Multiband Radio			

Figure 8-2. Chart C Aircraft Modification Example

Form F			
Make entries for items added as required on DD Form 365-4			
Weight and Balance Clearance Form F.			
ITEM DESCRIPTION	WEIGHT	ARM	MOM/1000
50 Cal Machine Gun Model AS-678	143.8	102.6	14.8
50 Cal Gun Mount	26.4	102.6	2.7
50 Cal Gun Control Harness	3.5	102.6	0.4

Figure 8-3. Form F Aircraft Modification Example

d. Weight and Balance Instructions for Modifications. The items listed in the Figure 8-1 - 8-3 charts are for example purposes only. Group new entries IAW Compartment, then Arm in an ascending order.

NOTE

Figure 8-3 Form F is required only for aircraft modifications that contain Form F items.

(1) Weight and Balance Data. In accordance with TM 55-1500-342-23, make entries on DD Form 365-1 Chart A as shown in Figure 8-1, on DD Form 365-3 Chart C as shown in Figure 8-2, and on DD Form 365-4 Form F (when required) as shown in Figure 8-3 and as discussed below:

(a) Chart A. Items that are removed are listed in Figure 8-1.

(b) Chart A. Items that are installed are listed in Figure 8-1.

(c) Chart C. Make entries for items removed/ added as shown in Figure 8-2. Ensure a Header and Footer that reflect the MWO are added to the Chart C.

(d) Form F. Make entries for items added as required on DD Form 365-4 Weight and Balance Clearance Form F as shown in Figure 8-3.

8.1.13 Contact Information. For weight and balance technical support, contact the POCs listed in paragraph 8.1.8d(1).

8.1.14 Corrections to This Manual. Submit DA Form 2028.

8.1.15 Weight and Balance Software. This technical manual does not provide authorization for any specific weight and balance software, to include AWBS.

8.1.16 Distribution of AWBS. AWBS may be obtained via the Joint Technical Data Integration (JTDI) website <https://www.jtdi.mil> under the AWBS Tab's software link.

a. Central Server. N/A.

8.2 US NAVY/US MARINE CORPS REQUIREMENTS.

NOTE

Use of AWBS is mandatory unless OPSEC precludes it. See paragraph 8.2.15.

8.2.1 Related References. Weight and balance personnel shall be familiar with the following related technical manuals (supplementary data to this manual) and other related documents:

a. Weight and Balance Handbook. A Weight and Balance Handbook shall be maintained on all active aircraft. Refer to paragraph 8.2.2c for requirements.

b. Chart A. Basic Weight Checklist Record for assigned aircraft model(s).

c. Chart E. Loading Data for assigned aircraft model(s).

d. Naval Aviation Maintenance Program, COMNAVAIRFORINST 4790.2 Series. The Weight and Balance section, Chapter 10, contains top-level guidance and direction regarding field weight and balance control for USN/USMC aircraft.

e. NATOPS General Flight and Operating Instructions, CNAF M-3710.7 Series. Chapter 4 contains direction regarding weight and balance clearance for flight.

f. The NATOPS Flight Manual(s) for Assigned Aircraft Model(s). NATOPS Flight Manuals contain weight and balance (center of gravity) operating limitations for specific aircraft models.

g. The NATIP Flight Manual(s) for Assigned Aircraft Model(s). NATIP Flight Manuals represent the primary reference for technical information required for safe and effective tactical employment, including safety-of-flight limitations and restrictions for specific aircraft models. NATIP documents the loading arrangements and limitations approved for permanent flight clearance.

h. Cargo Loading Manual. The cargo loading manual contains the description of the individual type aircraft

capabilities, provisions, systems and features for carrying cargo and troops. This document can also cover cargo type descriptions, loading instructions and procedures, cargo loading equipment operation and stowage, instructions for cargo load-out aircraft weight and center of gravity planning and calculations, cargo tie down calculations, and passenger/patient/troop accommodations installation, operation and removal procedures. This is essentially the "How to load the aircraft" manual.

i. NAVAIRSYSCOM Technical Directives System, NAVAIR 00-25-300. The Weight and Balance sections of the manual that describes the Technical Directives System.

j. NAVAIRSYSCOM Technical Library Management Program, NAVAIR 00-25-100. Contains information on technical manual (Aircraft Weight and Balance Handbook) controls.

8.2.2. Weight and Balance Control. Operational aircraft weight and balance control shall be accomplished in accordance with COMNAVAIRFORINST 4790.2 series (the Naval Aviation Maintenance Program (NAMP)), the specific aircraft NATOPS Flight Manuals, this manual, CNAF M-3710.7 series, and the specific aircraft Chart E - Loading Data.

a. In case of conflicting requirements, procedures, aircraft limits (weight and CG), authorized loadings, and/or instructions, COMNAVAIRFORINST 4790.2 series and the aircraft NATOPS/NATIP manuals shall take precedence over this manual and the specific aircraft Chart E pending mandatory resolution of the conflict from NAVAIRSYSCOM Mass Properties.

b. In the case of conflicting weight and balance loading data, the aircraft specific Chart E shall take precedence over the aircraft NATOPS/NATIP. Inclusion of weight and moment data in Chart E does not authorize loading arrangements. Check specific aircraft Chart C, Chart E and Form F for current weight and balance information for that aircraft. Weight and balance data in the aircraft NATOPS/NATIP (i.e. aircraft weights, stores weights, etc.) is provided for guidance only.

c. Weight and Balance Handbook. The Weight and Balance Handbook is the primary tool utilized in maintaining weight and balance control for aircraft. The weight and balance handbooks for individual aircraft shall be maintained in accordance with the requirements of this manual.

(1) The contents of an Aircraft Weight and Balance Handbook include the following six elements. Each section should be separated by a divider (if in hardcopy):

- (a) Record of Weight and Balance Personnel.
- (b) Chart A.
- (c) Forms B.
- (d) Chart C.
- (e) Chart E.
- (f) Forms F.

(2) The weight and balance handbook shall take the highest security classification of the data contained therein.

NOTE

AWBS aircraft files contain four of the six elements comprising a complete handbook: Personnel Record, Chart A, Form(s) B and Chart C. Forms F are created by each operational user or unit and are not part of the AWBS aircraft file. Chart E is a separate file from the AWBS aircraft file and is common for the TMS.

The following aircraft are not required to maintain a hard copy of the Handbook: F-35B/C.

(3) Form Availability:

(a) The following may be obtained from the Navy Data Distribution System (NDDS) at <https://ndds.navair.navy.mil> or by contacting NAVAIRSYSCOM Mass Properties.

1 TMS specific Chart A for delivery aircraft by lot, re-baselined configuration or major upgrade.

2 TMS specific Chart E.

3 AWBS Auto Limits File(s).

(b) The Joint Technical Data Interface website contains specific TMS data (including some weight and balance applications) for the C-130, MV-22 and H-60 at <https://www.jtdi.mil>.

(c) All required USN/USMC weight and balance technical data required for program support may be requested from NAVAIRSYSCOM Mass Properties.

8.2.3 Responsibilities.

a. NAVAIRSYSCOM Mass Properties Responsibilities. NAVAIRSYSCOM shall maintain overall responsibility for establishing the requirements, processes, procedures, and forms format for USN/USMC aircraft weight and balance control. NAVAIRSYSCOM Mass Properties is the office of primary responsibility for the following duties:

(1) Establishing technical content and format of the USN/USMC service specific requirements of this manual and coordination with other services regarding general sections of this manual.

(2) Approval/review for technical content and format of Charts A and E for individual aircraft models.

(3) Make available TMS specific Chart A for delivery lot aircraft and for major upgrades or re-baselined configurations as warranted.

(4) Make available current Chart E for all active aircraft.

(5) Create Auto Limits files when necessary and make them available for operational use.

(6) Act as the USN/USMC Technical POC for the Automated Weight and Balance System (AWBS) software.

(7) Determination and specification of USN/USMC aircraft weight and balance classifications.

(8) Provide specialized weight and balance engineering support to test, maintenance, and operating commands.

(9) Coordinate and recommend changes to the weight and balance requirements of COMNAVAIRFORINST 4790.2 series, CNAF M-3710.7 series, and NAVAIR 00-25-300 instructions.

(10) Coordinate and recommend changes to weight and balance training course content maintained by the Center for Naval Aviation Technical Training (CNATT).

(11) Coordinate and recommend procedures and/or equipment required for compliance with various requirements of the weight and balance control system.

(12) Prepare, obtain and disseminate aircraft weight and balance data that operational Commands require to comply with USN/USMC aircraft weight and balance control system requirements.

(13) Establish weighing intervals for aircraft.

(14) Technical assessment and approval of automated Form F generators.

(15) Qualification of Personnel Assigned Responsibility For Weighing Aircraft. NAVAIRSYSCOM Mass Properties shall verify that the personnel assigned the responsibility for weighing aircraft meet the qualification requirements of this document. Mass Properties shall maintain a record of qualified personnel and shall produce and disseminate a Letter of Qualification to Weigh Aircraft for personnel meeting the requirements.

b. Training Group Responsibilities. The Center for Naval Aviation Technical Training (CNATT) shall prepare and provide introductory weight and balance training required for Command compliance with the USN/USMC aircraft weight and balance control system. CNATT shall coordinate course content and special training procedures with NAVAIR Mass Properties to ensure content is appropriate and meets applicable standards. NAVAIRSYSCOM Mass Properties must approve all course revisions prior to implementation.

c. Depot Level Maintenance Responsibilities. Fleet Readiness Centers (FRCs) shall weigh aircraft and update individual aircraft Weight and Balance Handbooks in accordance with the requirements of COMNAVAIRFORINST 4790.2 series and this manual.

The FRCs shall ensure that a dedicated staff of qualified personnel are available to accomplish the required tasks and shall designate the Lead Weight and Balance Specialist responsible.

d. Type Commander / Aircraft Controlling Custodians/ Functional Wing Responsibilities.

(1) Shall ensure that reporting custodians and FRCs meet the requirements of COMNAVAIRFORINST 4790.2 series, CNAF M-3710.7 series and this manual.

(2) Shall perform periodic Aviation Maintenance Inspections (AMI) to evaluate the activities compliance with Weight and Balance requirements of COMNAVAIRFORINST 4790.2 series, CNAF M-3710.7 series, NAVAIR 00-25-300, NAVAIR 00-25-100, and this manual.

e. Aircraft Reporting Custodian Responsibilities.

(1) Aircraft Reporting Custodians are activities with an allowance of aircraft, an inventory of aircraft, or both.

(2) For weight and balance purposes, when an aircraft is in the physical custody of an activity, that activity is responsible for the maintenance of all weight and balance records. When an aircraft is inducted into off-site rework facility or is on loan to another activity, the weight and balance records shall accompany the aircraft and be maintained by the physical custodian.

(3) The Reporting Custodian shall designate a Weight and Balance Officer for the activity and any additional qualified Weight and Balance Personnel (Weight and Balance Technicians), in accordance with COMNAVAIRFORINST 4790.2 series.

(a) The Maintenance Material Control Officer (MMCO) shall be designated as the Weight and Balance Officer for the activity.

(b) The Commanding Officer of commands that employ temporary detachments away from the squadron, has the authority to designate a Weight and Balance Officer for each detachment if not the MMCO.

(c) These individuals must meet the qualifications for designation in accordance with the COMNAVAIRFORINST 4790.2 series.

(d) The Monthly Maintenance Plan (MMP) shall list designated individuals.

(e) Weight and Balance Technicians are personnel maintaining weight and balance records under the authority of the Weight and Balance Officer as designated in the MMP. This designation shall indicate their level of authority, based on their individual qualifications.

(4) Reporting Custodians shall ensure that weight and balance control system requirements and procedures of this manual and related technical documentation are complied with in accordance with the management procedures of COMNAVAIRFORINST 4790.2 series and CNAF M-3710.7 series. Weight and balance control system requirements and procedures shall include, but are not necessarily limited to ensuring:

(a) Weight and balance handbooks for all assigned aircraft, including newly received aircraft, are complete, current, and maintained in the correct format.

(b) Procedures are in place to ensure completion of weight and balance flight clearance per CNAF M-3710.7 series, the TMS specific loading manual, and this manual.

(c) Weight and balance impacts due to changes incorporated shall be properly recorded in the weight and balance handbooks of each aircraft affected by the change. Such changes include Technical Directives, Interim Flight Clearances, repairs, or other modifications.

(d) Concerns regarding accuracy of weight and balance data for any assigned aircraft are resolved satisfactorily, for example, by having aircraft weighed by an authorized weighing facility or field team.

(e) Ensure that Aircraft Battle Damage Repair (ABDR) actions do not result in unacceptable impacts on aircraft weight and balance.

NOTE

The MMCO or Lead Weight and Balance Specialist have the discretion to determine what is unacceptable.

(f) Configuration of aircraft with proper amounts of ballast as required to maintain the aircraft within the prescribed CG limits throughout its flight. The addition of ballast shall not compromise structural integrity of the aircraft and therefore any new ballast shall be approved by NAVAIRSYSCOM Mass Properties before it can be installed. Whenever ballast is required to balance an aircraft after the removal of equipment, placement of temporary ballast in the vacant equipment mounts up to the weight of the removed equipment is acceptable.

(g) When necessary, commands may impose more stringent requirements for weight and balance control through command supplements to applicable service manuals and instructions.

(h) The reporting custodian may request permission, via proper chain of command, to implement procedures to simplify aircraft weight and balance maintenance that do not conflict with this manual, the aircraft specific loading manual, or other applicable directives. Permission is required from NAVAIRSYSCOM Mass Properties for alternate procedures.

f. Commercial Maintenance Responsibilities. Commercial activities involved in the weight and balance control of USN/USMC aircraft shall comply with requirements in paragraphs 8.2.3c, 8.2.3e, and 8.2.4 as applicable.

8.2.4 Personnel Qualification Requirements.

a. Military and government civilian personnel must be qualified as shown in Table 8-1.

(1) When requesting a Letter of Qualification for a Lead Weighing Official from NAVAIRSYSCOM Mass Properties, provide evidence of course completion and Forms B as required.

(2) Exceptions to these requirements and approval of equivalent training that fulfills the intent of the qualification requirements must be obtained from NAVAIRSYSCOM Mass Properties.

(3) Personnel qualified to weigh a Type-Model by another Department of Defense service are qualified to weigh the same USN/USMC Type-Model.

Table 8-1. Qualification Requirements

Establishing Qualification Requirements		Weight and Balance Officer	Weight and Balance Technician	Lead Weighing Official	Lead Weight and Balance Specialist at FRC
Qualify for Designation	Training courses required by COMNAVFORINST 4790.2, or	Complete One			
	Commercial equivalent				
Maintaining Weight and Balance Records	Aircraft Weight and Balance Course, C-516-0001, or		Complete One		
	Equivalent required by COMNAVFORINST 4790.3, or				
	Course Number 088980ILT01 offered by Lockheed Martin, or				
	Aircraft Weight and Balance Course offered by General Electroynamics (GEC), or				
	Commercial equivalent				
Completing Forms F	TMS training syllabus, or		Complete One		
	Aircraft Weight and Balance course, C-516-0001, or				
	Equivalent required by COMNAVFORINST 4790.2				
Weighing Aircraft	Training Course required by COMNAVFORINST 4790.2, or			Complete One	Complete One
	Aircraft Weight and Balance Course AND AWBS course offered by Society of Allied Weight Engineers (SAWE), or				
	Course Number 088980ILT01 offered by Lockheed Martin, or				
	Aircraft Weight and Balance Course offered by General Electroynamics (GEC)				
	Aircraft Weighing Course offered by Society of Allied Weight Engineers (SAWE)			Complete	Complete
	Documented experience weighing at least 20 aircraft of four different TMS within previous year, or			Complete One	
	Six weighings of one TMS within previous year when authority will be limited to that TMS				
	Twelve months actual experience weighing at least sixty aircraft of at least five different TMS over past two years				Complete

NOTE

As an example, USAF personnel qualified by the USAF to weigh an F-35A are qualified to weigh the F-35B and/or F-35C.

b. NAVAIRSYSCOM Mass Properties shall verify that civilian contractor personnel have met the intent of the qualifications of this section.

(1) When requesting a Letter of Qualification for civilian contractor personnel from NAVAIRSYSCOM Mass Properties, provide the following:

(a) A statement specifically requesting which function(s) the person is to be qualified (e.g. Weight and Balance Technician).

(b) A statement that the person has met internal company training requirements for the function(s) requested.

(c) Certificates from courses required to meet internal company training requirements.

(d) If applicable, Forms B or equivalent for the TMS(s) for which the civilian contractor is seeking qualification.

c. Maintaining Qualification.

(1) Weight and Balance Officers, Weight and Balance Technicians, and Aircrew personnel completing DD365-4 Clearance Forms F or equivalent maintain their qualifications for 5 years after assignments out of the above responsibilities. After 5 years, these personnel must re-qualify per requirements in Table 8-1.

(2) Lead Weighing Official and Personnel Assigned Responsibility for Weighing Aircraft. In order for personnel assigned responsibility for weighing aircraft to maintain their qualification, they must weigh one aircraft of each authorized TMS every two years. Personnel must re-qualify per requirements in Table 8-1 if they fail to meet this requirement within the two-year period. Weighing personnel should maintain records of aircraft weighed to justify maintaining their qualification.

8.2.5 Retention and Disposition of Records / Charts / Forms. Weight and balance records for aircraft stricken from the Navy inventory are disposed of in accordance with the requirements of COMNAVAIRFORINST 4790.2 series with all other aircraft logs and records.

NOTE

Refer to SECNAV M-5210.1 series for procedures for transferring records to the Washington National Records Center. SECNAVINST 5510.30 series provides guidance for shipping classified information to the Washington National Records Center.

a. Records / Charts / Forms Retention.

(1) AWBS Personnel Record or DD 365 equivalent: permanent record.

(2) AWBS Chart A or DD 365-1 equivalent: Chart A shall be retained to trace Basic Weight/Moment/CG to the last aircraft weighing. Before applying an AWBS Master Chart A, the current Chart A, with all inventory histories, must be printed and retained until the aircraft is weighed again. Chart A history may be disposed of after the next weighing. After an AWBS Master Chart A has been applied, an inventory shall be completed to verify the in/out status of Chart A items.

(3) AWBS Form B or DD 365-2 equivalent: permanent record.

(4) AWBS Chart C or DD 365-3 equivalent: permanent record.

(5) Chart E: maintain the current version authorized by NAVAIRSYSCOM Mass Properties. If updated between weighings, retain the superseded copies in the superseded section until the next aircraft weighing. It may be disposed of after the next weighing.

(6) AWBS Forms F, authorized electronic equivalents or DD 365-4 equivalent:

(a) One-time Use Forms F: retain for three (3) months in accordance with CNAF M-3710.7 series. Refer to paragraph 8.2.7a(3).

(b) Standardized Loading (formerly CANNED) Forms F: retain for three (3) months after superseded. Refer to paragraph 8.2.7a(4).

8.2.6 Aircraft Classifications.

a. For weight and balance purposes, USN/USMC aircraft are divided into two classifications, Class 1B and Class 2. Class 1A is not utilized by the USN/USMC.

b. Class 1B aircraft are those with published weight and CG limits that can be exceeded by normally employed loading arrangements and therefore need loading control.

c. Class 2 are aircraft with published weight and CG limits that can readily be exceeded by normally employed loading arrangements and therefore need a higher degree of loading control.

d. Weight and balance classification of USN/USMC aircraft are shown in Table 8-2. All models of the same series take on the same weight and balance classification unless specifically designated otherwise. For aircraft not specifically listed in Table 8-2, assume a Class 2 designation and contact NAVAIRSYSCOM Mass Properties for further information.

e. All series of the models listed in Table 8-2 shall be in the class designated.

Table 8-2. USN / USMC Aircraft Classification Assignments

AIRCRAFT TYPE	Class 1B	Class 2
FIGHTER/ATTACK	AV-8, F-5, F-16, F/A-18	F-35
PATROL / SURVEILLANCE		P-3, P-8
ELECTRONIC	E-2, E-6, EA-6, EA-18	EP-3
CARGO / TRANSPORT		C-12, C-130, C-144, C-2, C-20, C-26, C-35, C-37, C-38, C-40, C-9, Learjet 35/36
HELICOPTER	H-1, H-3, H-60	H-53
VIP HELO TRANSPORT		VH-3, VH-60, VH-92
TRAINER	NU-1, OH-58, T-2, T-34, T-38, T-39, T-44, T-45, T-6, TAV-8, TC-12, TH-57, TH-6, U-6, UH-72, X-26	
SPECIAL / UAV / OTHER		CMV-22, CV-22, MQ-4, MQ-8, MV-22, RQ-4, X-47

8.2.7 Form F.

a. Form F Procedures.

(1) All Forms F shall be completed in accordance with Chapter 4 of this manual.

(2) Weight and Balance Clearance Form F Tactical vs. Transport or DD 365-4 equivalent. It is up to the operating command to determine which version of the form to utilize. Generally, Class 2 aircraft utilize the Transport version and Class 1B aircraft utilize the Tactical version.

(3) One-time Use Forms F are prepared for single-instance use to reflect a specific loading configuration applicable to a specific serial number aircraft. They are generally used when the Command does not utilize a standardized loading approach or when an aircraft is loaded in a manner not represented by a standard loading. Superseded or canceled standard loadings shall be retained on file for 90 days.

(4) Standardized loadings (formerly CANNED Forms F) are prepared for repeated use to reflect a loading configuration that could apply to more than one aircraft of a given TMS. If the Basic Weight and/or Basic Moment of any of three baseline aircraft (discussed below) changes, all existing Forms F based on standard loadings using those aircraft must be replaced. One copy shall be inserted into the Handbook of the aircraft that changed and a second copy shall be made available to the aircrew during briefing. The second copy may be inserted into the Aircraft Discrepancy Book (ADB), if utilized, or elsewhere so long as it is readily available

to the aircrew. Standardized loadings shall be checked every 180 days for accuracy. New Forms shall be prepared whenever Chart C Basic Weight and/or moment change for any of the three baseline aircraft. If no changes are required, the Form F may be re-dated or a letter issued certifying it is still current. The letter shall list the serial number aircraft and Forms that were reviewed.

b. Standardized Loading Procedures. At the option of the Command, standard loadings for a given TMS may be utilized with the following procedures to accomplish weight and balance flight clearance:

(1) Examine the weight and balance handbooks of all aircraft of the TMS in the Command to determine which three serial number aircraft meet these criteria:

- (a) Most-forward Basic CG,
- (b) Most-aft Basic CG,
- (c) Heaviest Basic Weight.

(2) These three serial number aircraft may be used to establish a baseline for determining a standard loading arrangement that would enable all aircraft of the TMS to remain within limits.

(3) Once this loading arrangement has been verified to remain within limits for all three baseline aircraft, the standard loading can be used to create Forms F for other aircraft of the same TMS. Standard loading Forms F must be signed per paragraph 8.2.7d and distributed per paragraph 8.2.7a(4).

(4) Auto Limit files simplify and more accurately determine forward and aft CG limits when generating Forms F using AWBS. These files, unique to each TMS, automatically determine the weight and CG limits at various conditions of the weight buildup. Depending on the TMS, mission scenario, and loading conditions, there may be more than one Auto Limits file to apply. Use of Auto Limits files is strongly encouraged for TMS that do not have constant forward and aft CG limits and do not have a dedicated Form F generator. Aircrew responsible for completing Forms F are responsible to ensuring that the proper Auto Limits file is used depending on mission scenario and loading conditions.

(5) If an AWBS Form F has an Auto Limits envelope selected, the weight and CG limits will be updated as each aircraft's Basic Weight and Basic Moment are combined with the standard loading.

(6) If an Auto Limits envelope is NOT selected, the weight and CG Limits will NOT be updated as each aircraft's Basic Weight and Basic Moment are combined with the standard loading. In this case, if the operating limits vary based on Gross Weight, the most restrictive limits MUST be utilized.

(7) For purposes of weight and balance flight clearance, the standard loading Form F shall be referenced.

(8) Standard loadings are sensitive to changes incorporated into any of the three baseline aircraft such as incorporation of TDs, engine and equipment changes, modifications and repairs. Therefore, weight and balance handbooks for the baseline aircraft shall be monitored closely with regard to standard loadings. Incorporated changes that affect Basic Weight and Moment in any of the three baseline aircraft require re-checking of standard loadings to ensure operating limits are still maintained. Replace Forms F based on standard loading if the loading was affected due to changes incorporated in the baseline aircraft.

c. Form F Gear Up, Gear Down CG Limits and Gear Up Moment Change (GUMC) Discussion.

(1) In AWBS, fixed-wing and rotary-wing aircraft with retractable landing gear shall set the "CHECK LIMITS" to "VERIFY" for "TAKEOFF LIMITS, Gear Down CG", "TAKEOFF LIMITS, Gear Up CG", "LANDING LIMITS, Gear Up CG", and "LANDING LIMITS, Gear Down CG" unless otherwise specified in the Chart E.

(2) Aircraft with retractable landing gear need to consider the moment impact due to gear retraction. The Gear up Moment Change (GUMC) quantifies this moment. The aircraft's GUMC shall be listed in Chart E, if applicable, and is entered into the Aircraft Description section in AWBS for each BUNO. The value entered must be in simplified form taking into account the moment simplifier for the TMS. Aircraft with fixed landing gear have a GUMC of zero.

d. Form F Signatures.

(1) Computed By: The signature of the individual completing the Form F. Must be qualified per paragraph 8.2.4a.

(2) Weight and Balance Authority: The signature of the Weight and Balance Officer or qualified member of the aircrew when on detachment. At the completion of the flight, all one-time use Forms F shall be delivered to the Weight and Balance Officer for review and verification screening. After screening, the Weight and Balance Office shall sign in the Weight and Balance Authority block or initial next to an existing signature and retain the form on file for 3 months in accordance with CNAF M-3710.7 series.

NOTE

Certification of Safe for Flight for One Time Use Forms F for weight and balance purposes does not require the Weight and Balance Officer's signature prior to takeoff, as he/she may not be present at that time.

(a) When selected, AWBS enables Weight and Balance personnel to digitally sign Forms F using the PKI certificate on the user's CAC. For clarification purposes, this is not a full digital CAC signature at this time. Use of AWBS electronic signature stamp is authorized for all USN/USMC aviation activities. Selection of any one, all three, or any combination of signature blocks is possible but only one PKI certificate will apply.

NOTE

AWBS electronic signature stamps are not mandatory, but they are authorized for use. Use of PDF copies of Forms F with digital CAC signature, as well as pen and ink stamp all remain as viable options.

(3) Pilot. The signature of the Pilot shall appear on all One-time Use Forms F. The pilot's signature is not required when using a standardized Form F. Enter "As Assigned" in this case.

e. Authorized Substitutions for DD Form 365-4. NAVAIRSYSCOM Mass Properties may authorize manual or electronic substitutions for DD Form 365-4 Form F.

8.2.8 Aircraft Weighings Requirements.

NOTE

It is acceptable to base the weight and CG on the Form B and Chart C of new production aircraft using the weight and CG of another aircraft in that same production lot.

a. When using AWBS, Chart A items shall not be listed in COLUMN I or COLUMN II with the exception of Trapped and Unusable Fuel if listed as Chart A items. The IN AIRCRAFT status of Chart A items in the inventory shall be consistent with the condition at weighing when using AWBS. If Chart A items are added or removed subsequent to weighing, AWBS enables such changes to be made easily.

NOTE

The listing of Chart A items in COLUMN II on Form B combined with Chart A inventory status as 'IN' leads to uncertainty.

b. Aircraft shall be weighed when any of the following conditions exist:

(1) As specified in technical directives or technical orders.

(2) When weighing requirements are specified in the applicable Chart E or other document.

(3) Before returning to flight after completion of standard rework processes (e.g. Standard Depot Level Maintenance (SDLM), Enhanced Phase Maintenance (EPM), Selected Planned Maintenance Interval (PMI), etc.) to include but is not limited to scheduled/unscheduled strip and/or paint events.

(4) When major modifications or repairs are made that meet the following guidelines:

(5) The MMCO or Lead Weight and Balance Specialist shall determine when an aircraft has undergone a "major modification or repair". As a guideline, a major modification or repair is one that affects 2% of Basic Weight or 500 lb., whichever is less, or changes the Basic Weight CG by 0.5% MAC for fixed-wing or 0.5 inches for rotary-wing. Determination of affected weight is based on the weight sum of items removed (excluding Chart A items) plus the weight sum of items added (excluding Chart A items). Affected weight is not the resultant change or difference between the two sums. All "major modifications or repairs" shall require the vehicle to be weighed prior to return to flight. For technical directives, this shall be verified during the Validation and Verification process prior to the TD being issued.

NOTE

Overhaul or major airframe repairs to include the replacement of major structural members such as spars, wings, tail booms, etc. Chart A items are excluded, as are aircraft engines, when determining weight affected.

(6) When aircraft modifications or repairs are accomplished and calculated or actual weight and moment data are not available.

(7) When the calculated weight and balance data are suspected to be in error.

(8) When unsatisfactory flight characteristics are reported that cannot be attributed to improper loading, an error in weigh and balance data, or any other identifiable cause.

(9) When an aircraft is in a depot facility or other authorized and capable weighing facility for any reason, and has not been weighed in five (5) years, (i.e. the most recent "as-weighed" Basic Weight entry in the Chart C is more than five (5) years ago).

(a) If an aircraft was last weighed more than five years ago and it is managed by a formal maintenance plan that requires periodic weighing (e.g. PMI within an Integrated Maintenance Plan (IMP)), then the aircraft should be weighed according to that plan. If the aircraft is not managed by a plan that requires periodic weighing, then the aircraft should be weighed at the next opportunity when it is in an authorized and capable facility.

(10) Whenever inactive aircraft become active. (Reference Chapter 3, paragraph 3.7).

(11) When the weight and balance handbook cannot be replaced using historical records.

c. Weighing Intervals. See paragraph 8.2.8b(9) and 8.2.8b(9)(a).

8.2.9 Transfer / Acceptance Inventory.

a. A complete inventory of Chart A items shall be performed whenever an activity accepts an aircraft from another custodian. This includes aircraft on temporary loan or off-site rework/mod.

NOTE

If there is no change in custodian, i.e. FRC rework that will not require a weighing, an inventory does not have to be performed during this evolution.

Some aircraft (e.g. F-35) have provision to conduct an electronic inventory. This is an acceptable alternative to performing a visual inventory of compartments.

b. This Chart A inventory is not to be confused with the Aircraft Inventory Record inventory performed for parts tracking/accountability and the Chart A inventory should not be performed until the aircraft has been configured for operations.

c. In addition, a screening of all technical directives that have been incorporated since the last weighing shall be performed. If a TD has been incorporated since the last weighing, verify the Chart A and Chart C entries have been made correctly, if applicable.

d. Technical directives incorporated since the last weighing may be obtained by identifying the date of the last weighing and comparing it to the Aircraft's Logbook, Technical Directives Section on CNAF FORM 4790/24A, Technical Directives Form and the DECKPLATE Incorporation Listing for Equipment Report LIST 04 Technical Directives Requirements.

e. The activity giving up an aircraft shall use the Transfer the Aircraft to Another Unit feature using the Central Server function in AWBS. This requires identifying the receiving unit in order to upload to the server.

f. If the Central Server is not used, the activity giving up an aircraft shall export the aircraft record to a file, copy the file to recordable media and send the media to the receiving unit.

g. The receiving unit shall download the aircraft from the Central Server or copy the aircraft file from recordable media and import the aircraft record into an AWBS database. After the AWBS file has been imported into the database of the receiving organization, verify the correct limits are set in the Form F Generator or on all existing Forms F applicable for that aircraft.

8.2.10 Scales.

a. Scale Calibration. All scales and load cells utilized to weigh USN/USMC aircraft by organic USN/USMC activities shall be calibrated per the requirements set by Naval Surface Warfare Center (NSWC) Corona and published in NA17-35MTL-1 Metrology Requirements List. Scales used by commercial activities shall be calibrated on a cycle in accordance with the commercial activity engineering, commercial activity metrology, and scale manufacturer policies and recommendations.

b. Scale Accuracy. All scales utilized to weigh USN/USMC aircraft shall be calibrated to 0.1 percent of the applied load between 10% and 90% of capacity.

NOTE

Applied load means the load at the reaction point (i.e. the weight the scale is measuring), not the total aircraft weight.

c. Scale Resolution. Not only must the scale be calibrated to be accurate but the scale resolution must also be set to indicate accurate precision.

d. Scale Selection and Usage.

(1) All USN/USMC aircraft that have wheel-type gear shall be weighed on stationary pit-type platform scales (reference Chapter 5, paragraph 5.2.1) or portable platform aircraft scales (reference Chapter 5, paragraph 5.2.2) unless prior approval from NAVAIRSYSCOM Mass Properties is obtained to use electronic weigh kits (load cells) (reference Chapter 5, paragraph 5.2.3). Aircraft with skid-type landing gear can only be weighed using load cells and therefore do not require NAVAIRSYSCOM Mass Properties approval. Chart E weighing procedures that include using load cells constitute NAVAIRSYSCOM Mass Properties approval to use load cells.

Table 8-3. Minimum and Maximum Load vs. Scale Capacity

Scale Capacity (lbs.)	Minimum Load (lbs.)	Maximum Load (lbs.)
2,500	250	2,250
5,000	500	2,250
15,000	1,500	13,500
30,000	3,000	27,000
60,000	6,000	54,000

Table 8-4. Minimum Load and Display Resolution

Calibrated Display Resolution (lbs.)	Minimum Allowable Load (lbs.)
0.1	100
1	1,000
2	2,000
5	5,000
10	10,000

(2) Scales shall be properly matched to the anticipated loads on each scale. Scales are properly matched when the anticipated load is greater than 10% and less than 90% of capacity as shown Table 8-3 and the anticipated load exceeds the minimum for the display resolution per Table 8-4.

8.2.11 Unmanned Aerial Vehicles/Systems (UAV / UAS). Unique requirements of Unmanned Aerial Vehicles/Systems allow for a deviation to this manual. Small UAV/UAS may not be required to maintain weight and balance handbooks. However, an approved weight and balance system shall meet the objectives of this manual. Prior approval from NAVAIRSYSCOM Mass Properties is required to implement an alternate weight and balance program for UAVs/UASs. In general, any UAV/UAS that has a Take-Off Gross Weight greater than or equal to 1320 pounds is classified as a Class 2 aircraft and requires a complete operational weight and balance system in accordance with this manual.

8.2.12 Weight and Balance Guidance for Aircraft Modifications.

a. NAVAIR 00-25-300, Naval Air Systems Command Technical Directive System Management and Procedures Manual is intended to furnish the Naval Aviation Enterprise (NAE) policy, processes, and guidance for Development and Management for Technical Directives/ Aircraft Modifications.

b. NAVAIR 00-25-300 contains specific information on the procedures for updating weight and balance records as a result of technical directives. Weight and Balance personnel shall become familiar with Appendix A for guidance.

c. If the Weight and Balance paragraph of a TD is suspected to be in error, immediately contact the immediate superior in command (i.e. Wing/MAG/MALS, etc.) for resolution. If unavailable, email NAVAIRSYSCOM Mass Properties for resolution, and submit a TPDR via JDRS at <https://jdrs.mil>. The category of the TPDR will be dependent on the severity of the finding.

8.2.13. Contact Information. Contact information for NAVAIRSYSCOM Mass Properties:

E-mail: weight&balance@navy.mil
MAILING ADDRESS:
NAVAL AIR SYSTEMS COMMAND
Mass Properties, BLDG 2885
22072 Sears Road
Patuxent River, MD 20670

8.2.14 Corrections to This Manual. Changes or corrections to this manual are made through normal technical manual change procedures by submitting a Technical Publication Deficiency Report (TPDR) to the Naval Air Technical Data and Engineering Service Command (NATEC) using the Joint Discrepancy Reporting Program (JDRS) at <https://jdrs.mil>. Corrections to TMS specific Charts A and E shall be directed to NAVAIRSYSCOM Mass Properties using the contact information in paragraph 8.2.13.

8.2.15 AWBS Requirements.

a. The use of AWBS and Central Server is mandatory for all USN/USMC activities unless operational security (OPSEC) requires use of paper forms. Requests to deviate from AWBS require prior approval from NAVAIRSYSCOM Mass Properties.

b. The AWBS Central Server enables users to transfer, take ownership of, upload/backup and download/restore aircraft files. The Central Server shall be used as the primary method for backing up AWBS files. The address for the USN Central Server is <https://awbs.hill.af.mil/CentralUSN>. The address for the USMC Central Server is <https://awbs.hill.af.mil/CentralUSMC>. If OPSEC precludes using the Central Server, local backup of AWBS data is the only method to store and recover data.

c. Whether activities back up their data using the Central Server or not, they shall perform a local backup of their AWBS database using the schedule recommended by the software. This is critical for activities that utilize standardized loadings since the AWBS Central Server does not currently allow for backup of Forms F. In addition, a local backup will also include all other AWBS data (i.e. Master Charts A, Aircraft Modification Files, etc.).

CAUTION

It is strongly recommended that the secondary backup of AWBS data be on either removable storage media or to a network server to prevent the loss of data in the event of computer malfunction or loss.

d. AWBS does not completely replace the weight and balance handbook, nor will it replace the need for the user to apply their knowledge of performing aircraft weight and balance. It is simply a tool to perform weight and balance tasks more efficiently and more accurately.

e. If OPSEC requires, it is acceptable for activities to utilize the paper DD Form 365-4 Clearance Form F for one-time use, as required. In these cases, no AWBS deviation authorizations by NAVAIRSYSCOM Mass Properties are required.

f. AWBS software is available to Navy users by submitting a Move-Add-Change (MAC) request to NMCI to obtain it. Periodic AWBS "patches" may be made available through the AWBS website at <https://awbs.hill.af.mil/>.

g. AWBS software is available to USMC users through USMC.mil software distribution channels. Periodic AWBS "patches" may be made available through the AWBS website at <https://awbs.hill.af.mil/>.

h. All AWBS users shall maintain an account for the AWBS website. This will ensure notification of AWBS updates, notification of AWBS Technical Interchange Meetings, access to AWBS issue resolutions, and access to the AWBS Central Server.

8.3 US AIR FORCE REQUIREMENTS. This section defines the requirements, procedures, and Command responsibilities relative to the USAF aircraft weight and balance control system. The overall objectives of the system are to provide current and correct information regarding aircraft Basic Weight and Moment, and to maintain aircraft Gross Weight and CG within permissible limits. All commands are responsible to assure that all personnel assigned weight and balance responsibility on USAF aircraft are qualified by paragraph 8.3.4.

NOTE

It is the intent of this document to have completely electronic files where practical, if authorized by the appropriate Command and approved by the Weight and Balance Authority. However, a current backup will be maintained at all times to prevent loss of data.

8.3.1 Related References. Weight and balance personnel shall be familiar with the following related technical manuals (supplementary data to this manual) and other related documents:

- a. Aircraft -5 Series TO: Sample Basic Weight Checklists and Loading Data.
- b. Aircraft -6 Series TO: Scheduled Inspection and Maintenance Requirements.
- c. Aircraft -9 Series TO: Cargo Loading Manual.
- d. Aircraft -1-2 Series TO: Flight Manual.
- e. TO 35B2 Series: Aircraft Handling and Weighing Equipment.
- f. TO 00-5-1: AF Technical Order System.
- g. AFRIMS: Records Disposition Schedule.
- h. AFI 21 Series: Maintenance Management.
- i. AFI 11-215: Flight Manuals Program.
- j. TO 33K Series: Technical Manual for Scale Calibration.

8.3.2 Weight and Balance Control. Operational aircraft weight and balance control shall be accomplished in accordance with the detailed requirements and instruction of the specific aircraft -5 series TO and the requirements of this manual. In case of conflicting requirements, procedures, or instructions, the aircraft -5 series TO shall take precedence over this manual pending resolution of the conflict.

NOTE

For some aircraft it may be possible to have a completely electronic Weight and Balance handbook if authorized by the appropriate Command and approved by the Weight and Balance Authority. However, a current backup will be maintained at all times to prevent loss of data.

a. Weight and Balance Handbooks. An aircraft weight and balance handbook provides for the continuous record of the weight and balance of a particular aircraft. There are two types of weight and balance handbooks; a primary handbook (which is required for each aircraft), and an optional supplemental handbook (which is an abbreviated version of the primary handbook).

NOTE

A weight and balance handbook is required for all active aircraft. Inactive aircraft (flyable temporary storage, static display, ground training, aircraft battle damage repair, etc.) do not require current and up-to-date weight and balance handbooks. If these inactive aircraft become active, the weight and balance handbook will be updated with an actual weighing prior to first flight. If the weight and balance handbook is not available, it will be initiated in accordance with paragraph 8.3.2f.

b. Handbook Location. Class 1 aircraft weight and balance handbooks shall be stored in a location as determined by the commands. Class 2 aircraft primary weight and balance handbooks for non-fighter aircraft (See paragraph 3.6) shall be stored on the aircraft when the aircraft is in flight, or as determined by the command if a supplemental handbook is maintained for storage on the aircraft. Class 2 primary weight and balance handbooks for fighter aircraft shall be stored as determined by the commands.

c. Primary Handbooks. A primary weight and balance handbook shall be maintained for each assigned active aircraft by qualified weight and balance personnel. The handbook charts, forms, and, when required, the aircraft -5 series TO shall be maintained in accordance with requirements and instructions of this manual, TO 00-5-1 and AFRIMS - Record Disposition Schedule.

NOTE

If the -5 series TO is in the form of multiple TOs, only the Loading Data TOs need to be included. The Sample Basic Weight Checklist does not have to be included. If desired, the -5 may be maintained with each primary handbook.

(1) The contents of the primary weight and balance handbook shall be arranged and maintained in the following order:

(a) Locally developed cover page containing at least the MDS and Serial Number.

(b) DD FORM 365; RECORD OF WEIGHT AND BALANCE PERSONNEL.

(c) DD FORM 365-1; CHART A - BASIC WEIGHT CHECKLIST RECORD.

(d) DD FORM 365-2; B - AIRCRAFT WEIGHING RECORD.

(e) DD FORM 365-3; CHART C - BASIC WEIGHT AND BALANCE RECORD. If desired, only the Chart C since the last weighing need be maintained in this manual.

(f) Applicable aircraft -5 series TO, unless there is supplemental weight and balance handbook or the primary weight and balance handbook is permanently stored in a central location not on board the aircraft. This refers to the loading data section of the aircraft -5 series TO. It contains the information necessary to perform aircraft loading control (weight and balance flight clearance computations) and to accomplish actual weighing. In the above cases, an aircraft -5 series TO is not required with each primary handbook. One copy (minimum) of the aircraft -5 series TO which covers a group of similar aircraft shall be maintained, for reference purposes.

NOTE

If the -5 series TO is in the form of multiple TOs, only the Loading Data TOs need to be included. The Sample Basic Weight Checklist does not have to be included. If desired, the -5 may be maintained with each primary handbook.

(g) If desired, DD FORM 365-4; FORM F - WEIGHT AND BALANCE CLEARANCE FORM may be maintained or stored in the weight and balance handbook. This is advisable whenever someone other than the normal Weight and Balance Authority may be completing a Form F for this aircraft, such as when the aircraft is going to depot.

d. Supplemental Handbooks. Using Commands that maintain primary weight and balance handbooks in a central location shall assemble and maintain supplemental handbooks for storage on all Class 2 non-fighter aircraft. The maintenance of these supplemental handbooks shall be the responsibility of the individual assigned the responsibility for the primary handbook. As a minimum, supplemental handbooks shall include:

(1) A statement identifying the qualified person responsible for maintaining the handbooks, their duty station, office symbol, and phone number. This statement shall also note that changes to the aircraft Basic Weight and/or Moment shall be coordinated with the individual assigned responsibility for handbook maintenance.

(a) EXAMPLE. John/Jane Q. Doe, XXX BWG/AMQ, Best AFB, DSN XXX-XXXX is responsible for maintenance and update of the primary and supplemental weight and balance handbooks for aircraft Serial Number XX-XXX as authorized by TO 1-1B-50, Section 8. All changes affecting the Basic Weight and/or Moment of this aircraft shall be coordinated with them.

(2) A certified copy of the current (last page) DD Form 365-3, the AWBS substitute or locally generated form to provide the current aircraft Basic Weight, Basic Moment or Index, and CG location.

(3) The applicable aircraft -5 series TO.

NOTE

If the -5 series TO is in the form of multiple TOs, only the Loading Data TOs need to be included. The Sample Basic Weight Checklist does not have to be included.

e. Handbook Security Classification. Aircraft weight and balance handbooks shall be classified in accordance with the highest security classification of the data contained therein.

f. Handbook Replacement. In the event an aircraft's primary weight and balance handbook or pages becomes lost, is damaged, or for any reason needs to be replaced, the individual assigned responsibility for that aircraft handbook shall assemble a new handbook as follows:

(1) Obtain a new cover page containing at least the MDS and Serial Number.

(2) Obtain and complete a DD Form 365.

(3) Obtain sufficient copies of DD Form 365-1 and use the applicable aircraft -5 series TO to prepare a new Chart A.

(4) Inventory the aircraft.

(5) Obtain DD Form 365-2 and weigh the aircraft in accordance with applicable directives, then complete the DD Form 365-2.

(6) Obtain DD Form 365-3 and complete with initial entry from the DD Form 365-2. Include a note identifying the reason for assembling a new handbook.

(7) Obtain the applicable aircraft -5 series TO as required.

(8) Obtain and prepare DD Form 365-4; FORM F - WEIGHT AND BALANCE CLEARANCE FORM.

NOTE

If sufficient data is available to accurately reflect the aircraft's lost or damaged weight and balance data pages, as in the case of worn or water damaged pages or the AWBS, accomplish items 8.3.2f.(1) through 8.3.2f.(8) above as deemed necessary by the weight and balance authority. If there is not sufficient data to accurately duplicate the aircraft's lost or damaged pages or document, but sufficient data is available to assess the true weight and balance of the aircraft, only a note to the effect that the historical records cannot be duplicated, but the current weight and balance data is correct is all that is necessary.

g. Authorized Substitute Forms. Data sheets from the AWBS may be used in lieu of the DD Form 365, DD Form 365-1, DD Form 365-2, DD Form 365-3, and DD Form 365-4. Data sheets from computerized Form F generators may be used provided these sheets contain as a minimum, the necessary weight and balance data as defined by the DD FORM 365 series forms, -5 series TO, and this TO.

8.3.3 Responsibilities.

a. Training Group.

(1) AIR EDUCATION AND TRAINING COMMAND (AETC) RESPONSIBILITIES: AETC shall prepare and provide weight and balance instruction and training required for using unit compliance with USAF aircraft weight and balance control system.

b. Depot Level Maintenance.

(1) AIR LOGISTICS CENTER (ALC) RESPONSIBILITIES: The ALCs of AFMC shall prepare, procure, and disseminate aircraft weight and balance data that Commands require to comply with USAF aircraft weight and balance control system requirements. ALCs shall also provide and/or coordinate with AFLCMC technical assistance for unusual weight and balance problems as requested by commands. ALCs shall establish weighing intervals for aircraft not included in paragraph 8.3.3c(1)(h).

c. Type Commander / Air Force Life Cycle Management Center (AFLCMC) Responsibilities.

(1) AIR FORCE LIFE CYCLE MANAGEMENT CENTER (AFLCMC). The Air Force Life Cycle Management Center (AFLCMC) of the Air Force Materiel Command (AFMC) shall maintain overall responsibility for establishing the requirements, procedures, forms format, and AWBS for USAF aircraft weight and balance control. AFLCMC/EZFS is the office of primary responsibility for the following duties:

(a) Establishing the technical content and format of this manual, and the DD FORM 365 series forms.

(b) Provide recommendations to program offices concerning technical content and format of aircraft -5 series TOs for which AFLCMC has technical responsibility.

(c) Provide recommendations to program offices concerning AFTO Forms 22 and AF Forms 847 relative to documentation for which AFLCMC has technical responsibility.

(d) Determination and specification of USAF aircraft weight and balance classifications.

(e) Development of specialized weight and balance engineering services that may be requested by Air Logistics Centers (ALCs).

(f) Coordination and recommendations to Air Education and Training Command (AETC) of changes in the USAF aircraft weight and balance control system that may necessitate revising the training curriculum of weight and balance courses.

(g) Coordination and recommendation of procedures and/or equipment required for compliance with the various requirements of the weight and balance control system.

(h) Provide recommendations to program offices concerning weighing intervals for aircraft whose engineering responsibility is within AFLCMC.

(i) Acts as the USAF Technical OPR for the AWBS.

d. Command Responsibilities. Commands shall establish effective operating procedures for weight and balance control of aircraft assigned to their command to ensure:

(1) The weight and balance control system requirements and procedures of this manual, and related TO documentation, are in accordance with the management procedures of AFI 21-101. When necessary, the Commands may impose more stringent requirements for weight and balance control through Command supplements to applicable Air Force manuals and instructions. The weight and balance control system requirements and procedures shall include, but not necessarily be limited to:

(a) The updating of records to the current weight and balance status for all assigned aircraft.

(b) The development of methods for aircraft loading that are satisfactory for safety of flight.

(c) The proper utilization of modification weight and balance data.

(d) The proper completion of the Form F as required.

(e) Assisting flight crews in proper weight and balance maintenance.

(f) Equipment is available, maintained, and/or certified as required for compliance with the applicable weight and balance directives.

(g) The using unit may implement procedures to simplify aircraft weight and balance maintenance which do not conflict with the aircraft -5 series TO, this document, or other applicable directives.

(h) It is the responsibility of the weight and balance technician to determine the proper amounts of ballast required to maintain the aircraft within the prescribed CG limits throughout its flight.

8.3.4 Personnel Qualification Requirements.

a. Military and civilian personnel assigned the responsibility for accomplishing the various weight and balance functions (weight and balance technicians) are qualified (1) by graduating from an AETC approved course of instruction and (2) by the Weight and Balance Authority (as determined by the command) who will certify that the weight and balance individual has completed the training and maintains their proficiency. The approved course of instruction requires successfully completing (1) J6ANW2AXXX 0W1A (Computer Based Training) Aircraft Weight and Balance Course and (2) J3AZR2AXXX 0W1A Weight and Balance Practical Course (or AFLCMC/EZFS approved alternative mobile course). The Weight and Balance Authority may waive the J3AZR2AXXX 0W1A Weight and Balance Practical Course for individuals who are trained by current weight and balance qualified technician and certified by the Weight and Balance Authority. Individuals who have previously completed a formal AETC approved weight and balance course prior to implementation of the above courses have fulfilled the training requirement. The Weight and Balance Authority shall ensure the weight and balance technician is proficient in accomplishing weight and balance tasks on their assigned aircraft. The weight and balance authority is not required to be weight and balance certified, if they are not performing weight and balance tasks.

NOTE

Civilian contractor qualifications will be verified by the contractors engineering department or quality assurance office. Contractor's engineering department or quality assurance office may approve equivalent training that fulfills the intent of the above paragraph.

Exceptions to this requirement will be approved by AFLCMC/EZFS through the affected MAJCOM.

NOTE

Weight and balance personnel that do not have the responsibility to weigh aircraft are not required to complete the J3AZR2A000-000 Weight and Balance Practical Course, but will complete a MAJCOM approved AWBS familiarization course. AWBS training will be documented in the individuals training records or in an approved Maintenance Information System. The Weight and Balance Authority will ensure the weight and balance technician is proficient in accomplishing weight and balance documentation requirements on their assigned aircraft. These weight and balance personnel are NOT authorized to weigh aircraft.

8.3.5 Forms / Records Disposition. In accordance with AFRIMS - Record Disposition Schedule, the disposition of weight and balance documentation shall be as follows:

- a. Record of Weight and Balance Personnel. Destroy after loss of aircraft.
- b. Basic Weight Checklist Record (Chart A). Destroy after loss of aircraft or when superseded.
- c. Aircraft Weighing Record (Form B). Destroy after loss of aircraft or when superseded.
- d. Basic Weight and Balance Record (Chart C). Destroy after loss of aircraft.
- e. Weight and Balance Clearance Form F.
 - (1) Prepared for each mission. Destroy on completion of mission.
 - (2) Related to an aircraft involved in an accident. Destroy 1 year after completion of investigation.

f. Standardized (formerly CANNED) Form F.

- (1) Destroy when superseded.
- (2) Related to an aircraft involved in an accident. Destroy 1 year after completion of investigation.

8.3.6 Aircraft Classifications. See paragraph 3.6.

8.3.7 Form F.

a. Form F Procedures.

(1) Form F Maintenance Procedures. All Forms F shall be completed in accordance with the instructions of this manual. Forms F are utilized on a ONE TIME USE basis, or are standardized for multiple use.

(a) ONE TIME USE Form F. These are Forms F prepared for use on a one time basis and are destroyed upon mission completion. They are generally used when the Command does not utilize a standardized Form F approach or when an aircraft is loaded in a manner for which no standardized Form F is on file.

NOTE

For some aircraft it may be possible to have completely electronic ONE TIME USE Form Fs, if authorized by the appropriate Command and approved by the Weight and Balance Authority. However, a current backup will be maintained at all times to prevent loss of data.

(b) Standardized (formerly CANNED) Form F. These are Forms F which are prepared for multiple use when an aircraft's Basic Weight and Moment remain within certain specified tolerances. They are filed in accordance with established Command procedures, for future reference and use. Standardized Form F shall be checked at least every 180 days for accuracy and a new Form F prepared as required. New standardized Form F shall be prepared whenever Chart C Basic Weight and/or Moment changes accumulate to the threshold specified in the aircraft -5 series TO, or to the general requirements for Chart C threshold as specified in this TO. If no changes are required, the Form F may be re-dated and initialed, or a letter issued to state the review has been accomplished to certify its currency.

NOTE

For some aircraft it may be possible to have completely electronic standardized Form Fs, if authorized by the appropriate Command and approved by the Weight and Balance Authority. However, a current backup will be maintained at all times to prevent loss of data.

b. Standardized Loadings.

(1) At the option of the Weight and Balance Authority and when missions permit, the use of standardized aircraft loadings (usually for fighter/attack/trainer/rotary-wing aircraft), standardized Forms F may be utilized with the following procedures to accomplish weight and balance flight clearance:

(a) The weight and balance handbooks for Class 2 aircraft of the same MDS shall be examined to determine which aircraft have the:

- 1 Most forward Basic Weight CG location.
- 2 The heaviest Basic Weight.
- 3 And most aft Basic Weight CG location.

(b) These aircraft shall then be used as the baselines for calculation of aircraft weight and balance flight clearance. Additional aircraft may be used if desired or necessary for calculations of the aircraft weight and balance flight clearance.

(c) These baseline aircraft shall be used to compute Forms F to reflect carriage of the standardized load configurations on each aircraft. The standardized loadings for which all aircraft remain within safe weight and balance limits for takeoff, flight, and landing may then be standardized. These standardized Forms F shall be used for the weight and balance flight clearance of the remaining aircraft of the same MDS.

(d) For actual weight and balance flight clearance, these standardized Forms F shall be referenced for record purposes.

(e) Aircraft Basic Weight and CG location is constantly changing through the incorporation of TCTOs, engine and equipment changes, modifications, and repairs. Therefore, the weight and balance handbooks for all aircraft involved in these standard loading procedures shall be closely monitored. Aircraft Basic Weight and CG location shall remain within the weight, most forward CG and most aft CG conditions of the reference baseline aircraft.

c. Clearance Procedure. When filing DD Form 175, Military Flight Plan (or authorized substitute), pilots shall either attach the original copy of a ONE TIME USE DD Form 365-4 or note that a previously filed standardized DD Form 365-4 is applicable. Duplicate copies of DD Form 365-4 shall be filed in accordance with Command operational procedures (attached to flight plan or given to controlling ground agency, quality assurance, transient alert, maintenance, etc.). One of the following entries shall be made in the appropriate space on DD Form 175:

- (1) N/A - For Class 1 aircraft since weight and balance flight clearance is not required.
- (2) ATTACHED - When a ONE TIME USE DD Form 365-4 is attached.
- (3) FILED AT DATE - when citing a previously filed standardized DD Form 365-4.

d. Authorized Substitutions For DD Form 365-4. The following substitutes are authorized for use as weight and balance clearance records in lieu of DD Form 365-4.

- (1) Electronic Computer data sheets may be used in lieu of the DD Form 365-4 provided these sheets contain, as a minimum, the necessary weight and balance data as defined by the -5 series TO to show load computations, Gross Weight and CG. The date, aircraft serial number, and signatures of responsible personnel shall be documented on the sheet. The sheet does not have to resemble the style or format of the actual DD Form 365-4.
- (2) The designated commercial type loading schedule for C-9 aircraft.
- (3) Computer programs that only produce the DD FORM 365-4 forms shall follow the requirements in Chapter 6 of this Technical Manual.

8.3.8 Aircraft Weighing. When an aircraft is in a depot facility or other authorized weighing facility for any reason, and has not been weighed in five (5) years, (i.e., the most recent “as-weighed” Basic Weight entry in the Chart C is more than five (5) years ago). This applies unless a loading manual specifies a less restrictive requirement for a particular MDS aircraft.

8.3.9 Transfer / Acceptance Inventory. At the discretion of the losing/gaining weight and balance authority, the Chart A may be checked by an aircraft inventory whenever the AFI 21-103 possession changes and the Weight and Balance Authority changes.

8.3.10 Scales.

a. Scale Calibration. Scale calibration time intervals are determined by Air Force Metrology and Calibration (AFMETCAL).

b. Scale Accuracy. New scales shall have an accuracy of 0.1% of applied load or to the scale reading increment, whichever is greater. Recalibration of scales shall have the following accuracy requirements:

(1) 0.0% to 20.0% of scale capacity shall have an accuracy of 0.2% of applied load or to the scale reading increment, whichever is greater.

(2) 20.1% to 90.0% of scale capacity shall have an accuracy of 0.1% of applied load or to the scale reading increment, whichever is greater.

(3) 90.1% to 100.0% of scale capacity shall have an accuracy of 0.2% of applied load or to the scale reading increment, whichever is greater.

8.3.11 Unmanned Aerial Vehicles (UAVs). Unique requirements of Unmanned Aerial Vehicles (UAVs) weighing less than 3,000 pounds (Basic Weight) allow for a deviation from this manual when they are routinely weighed and balanced every time the vehicle is reconfigured. These small UAVs are not required to maintain weight and balance handbooks in accordance with this manual. However, an approved weight and balance system using forms and charts to calculate and record weight and balance data that meet the objectives of this manual shall be utilized.

8.3.12 Weight and Balance Guidance for Aircraft Modifications. TCTOs and modifications with changes less than two pounds for aircraft whose Basic Weight is under 25,000 pounds and changes less than five pounds for aircraft whose Basic Weight is over 25,000 pounds need not be recorded unless directed by TCTO or other directive.

8.3.13 Contact Information. AFLCMC/EZFS Mass Properties:

MAILING ADDRESS:
AFLCMC/EZFS (Mass Properties)
2145 MONAHAN WAY
BUILDING 28
WPAFB, OH 45433-7017

8.3.14 Corrections to This Manual. Changes or corrections to this manual are made through the normal technical manual change procedure by submitting a Technical Publication Deficiency Report (TPDR) through the Naval Air Technical Data and Engineering Service Command (NATEC) website, <https://www.natec.navy.mil>.

8.3.15 Distribution of AWBS / AFFs. AWBS software may be obtained through the AWBS website at <https://awbs.hill.af.mil>.

THIS PAGE LEFT INTENTIONALLY BLANK

8.4 US COAST GUARD REQUIREMENTS. This section defines the requirements, procedures, and responsibilities relative to the USCG aircraft weight and balance program. The overall objectives of the program are to provide current and correct information regarding aircraft Basic Weight and moment, and to maintain aircraft Gross Weight and CG within permissible limits. All commands are responsible to assure that personnel designated as weight and balance authorities on Coast Guard aircraft are qualified to perform the duties assigned.

8.4.1 Related References. Weight and balance personnel shall be familiar with the following related technical manuals (supplementary data to this manual) and other related documents:

- a. Aircraft -1 Series Publication: Aircraft Flight Manual.
- b. Aircraft -5 Series Publication: Sample Basic Weight Checklists and Loading Data.
- c. Aircraft/Airframe Specific Maintenance Procedure Cards.
- d. Aircraft/Airframe Specific Chart A - Basic Weight Check List.
- e. Aircraft -9 Series Publication: Cargo Loading Manual.
- f. COMDTINST M13020 Series: Aeronautical Engineering Maintenance Management Manual.
- g. COMDTINST M3710 Series: Coast Guard Air Operations Manual.
- h. CGTO PG-85-00-180: Aircraft Weight and Balance Process Guide.

8.4.2 Weight and Balance Control. Operational aircraft weight and balance control shall be accomplished in accordance with the requirements of CGTO PG-85-00-180 and the detailed instructions in aircraft -1 and -5 series publications in addition to the requirements of this manual. In case of conflicting requirements, procedures, or instructions, the aircraft specific publication shall take precedence over this manual pending resolution of the conflict.

a. Weight and Balance Handbooks. A weight and balance handbook is required for all active aircraft. An aircraft weight and balance handbook provides for the continuous record of the weight and balance of a particular aircraft. It is the primary tool utilized in maintaining weight and balance control for aircraft. Inactive aircraft (flyable temporary storage, static display, ground training, repair, etc.) do not require current and up-to-date weight and balance handbooks. If these inactive aircraft become active, the weight and balance handbook shall be updated with an actual weighing prior to first flight.

(1) Non-current copies of the charts and forms may be filed (paper or electronic) for historical purposes and shall be available whenever requested by ALC. These historical charts and forms shall be transferred with the aircraft whenever the aircraft is transferred. See CGTO PG-85-00-180 for handbook content information.

NOTE

If the -5 series publication is in the form of multiple publications, only the Loading Data needs to be included with each handbook. The Sample Basic Weight Checklist does not have to be included.

b. Handbook Security Classification. Aircraft weight and balance handbooks shall be classified in accordance with the highest security classification of the data contained therein.

c. Handbook Replacement. In the event an aircraft's weight and balance handbook or pages becomes lost, is damaged, or for any reason needs to be replaced, the individual assigned responsibility for that aircraft handbook shall assemble a new handbook. If electronic data is not locally available to reproduce the content, contact ALC Operations.

8.4.3 Responsibilities.

a. Aviation Training Center (ATC). ATC shall provide initial training of pilots on Basic Weight and balance concepts to include introduction to electronic forms of weight and balance management.

b. Aviation Logistics Center (ALC). ALC shall provide:

(1) Officials to certify the weight of Coast Guard aircraft.

(2) Accurate documentation reflecting aircraft configuration and baseline weight and balance.

(3) Access, training and utilization information to electronic applications utilized for aircraft weight and balance configuration management.

c. Air Station. Air Stations shall establish effective operating procedures for weight and balance configuration management of aircraft assigned to their command.

8.4.4 Personnel Qualification Requirements.

a. Military and civilian personnel assigned the responsibility for accomplishing the various weight and balance functions are qualified by completing an ALC approved course of instruction. Personnel that do not have the responsibility to weigh aircraft shall have training for familiarization of weight and balance chart and form maintenance.

NOTE

Civilian contractor qualifications will be verified by the contractors engineering department. Contractor's engineering department may approve equivalent training that fulfills the intent of the above paragraph.

8.4.5 Forms / Records Disposition. For information on disposition of forms and records refer to Aircraft Weight and Balance Process Guide CGTO PG-85-00-180.

8.4.6 Aircraft Classifications. Refer to the aircraft specific publications for loading control. All manned and unmanned aircraft where weight and balance class is not stated in the aircraft specific publications shall be considered Class 2. Class 2 aircraft are those with published weight and CG limits that can be readily exceeded by normally employed loading arrangements and therefore need a higher degree of loading control.

8.4.7 Form F.

a. Form F Maintenance Procedures. Electronic data sheets from approved Form F generators may be utilized in lieu of DD Form 365-4. See CGTO PG-85-00-180. All Forms F shall be completed in accordance with the instructions of this TO. Forms F are utilized on a ONE TIME USE basis, or are standardized for multiple use.

(1) ONE TIME USE Form F. These are Forms F prepared for use on a one time basis and are destroyed upon mission completion. They are generally used when the Air Station does not utilize standardized Forms F or when an aircraft is loaded in a manner for which no CANNED Form F is on file.

(2) CANNED Form F. These are Forms F which are prepared for multiple use when an aircraft's Basic Weight and moment remain within certain specified tolerances. They are filed in accordance with established Air Station procedures, for future reference and use. New standardized Forms F shall be prepared whenever Chart C Basic Weight and/or moment changes.

b. Standardized Loadings.

(1) Standardized (formerly CANNED) Forms F. At the option of the Air Station weight and balance personnel and when missions permit, the use of standardized aircraft loadings, standardized Forms F, may be utilized ensuring that the aircraft remains within its most forward and aft CG configuration.

(2) Aircraft Basic Weight and CG location is constantly changing through the incorporation of TCTOs, equipment changes, modifications, and repairs. Therefore, the weight and balance handbooks for all aircraft involved in these standard loading procedures shall be closely monitored. Aircraft Basic Weight and CG location shall remain within the weight limits, most forward CG and most aft CG conditions of the aircraft.

8.4.8 Aircraft Weighings.

a. Aircraft Weighing Requirements. Aircraft shall be weighed when any of the following conditions exist:

(1) At initial delivery to Coast Guard inventory.

(2) Following Programmed Depot Maintenance (PDM).

(3) When TCTOs, modifications or structural repairs are made that affect the weight and balance of the aircraft and calculated or actual weight and moment data are not available.

(4) When the calculated weight and balance data is suspected of being in error.

(5) When the aircraft is painted and the weight and balance impact has not been provided.

NOTE

Painting can drastically change aircraft weight and balance. If an aircraft is completely painted (many aircraft -5 series technical orders have more restrictive requirements), and the responsible Service Engineering Organization has not evaluated and provided the weight and balance impact for the work accomplished, the aircraft will be weighed.

(6) When unsatisfactory flight characteristics are reported which cannot definitely be determined as caused by faulty flight control system, improper loading, or error in weight and balance data and/or computations.

(7) Whenever specified by ACMS.

b. Weighing Intervals. Aircraft will be weighed during scheduled PDM and as required per applicable aircraft publications or ALC Product Line Engineering.

8.4.9 Transfer / Acceptance Inventory. A complete Chart A inventory shall be accomplished whenever possession changes as directed by individual aircraft maintenance procedure cards (MPC).

8.4.10 Scales.

a. Scale Calibration. Scale calibration intervals are determined by scale manufacturer recommendations.

b. Scale Accuracy.

(1) New scales shall have an accuracy of 0.1% of applied load. Recalibration of scales shall have the following accuracy requirements:

(a) 0.0% to 20.0% of scale capacity shall have an accuracy of 0.2% of applied load.

(b) 20.1% to 90.0% of scale capacity shall have an accuracy of 0.1% of applied load.

(c) 90.1% to 100.0% of scale capacity shall have an accuracy of 0.2% of applied load.

(2) Individual scales shall not be used when the applied load (i.e. reaction to be measured when weighing the aircraft) is less than the lowest load applied during scale calibration.

NOTE

Aircraft scales are usually calibrated in increments of 10% of the scale capacity. For example, a 60,000 lb. capacity scale calibration record usually shows the lowest load applied during calibration is 6,000 lb. (10% of scale capacity).

(3) If the weighing technician intends to use a scale to measure applied loads that are less than 10% of the scale capacity, the scales shall be calibrated to lower applied loads and documented in the scale calibration records.

(4) Do not use a scale whose display increment is less than the required 0.1% calibration accuracy.

NOTE

For example, if the scale displays in increments of 10 pounds it will not be used to measure an applied load of 10000 pounds or less.

8.4.11 Unmanned Aerial Vehicles (UAVs). Unique requirements of Unmanned Aerial Vehicles (UAVs) weighing less than 3,000 pounds allow for a deviation from this TO when they are routinely weighed and balanced every time the vehicle is reconfigured. These small UAVs are not required to maintain weight and balance handbooks in accordance with this TO. However, an approved weight and balance system using forms and charts to calculate and record weight and balance data that meet the objectives of this paragraph shall be utilized.

8.4.12 Weight and Balance Guidance for Aircraft Modifications. See Aircraft Weight and Balance Process Guide CGTO PG-85-00-180 and TCTO/SCTO Process guide CGTO PG-85-00-40-A.

8.4.13 Contact Information. ALC Operations Division. For information on the Coast Guard Weight and Balance program visit:

<https://cgportal2.uscg.mil/units/alc/SitePages/WBWEBSITE.aspx>

MAILING ADDRESS:

USCG Aviation Logistics Center
Operations Division
Weight and Balance Program Manager
1664 Weeksville Road, BLDG 64
Elizabeth City, NC 27909 - 5001

8.4.14 Corrections to This Manual. Corrections to this manual will be through utilization of the CG-22 system.

8.4.15 Distribution of AWBS.

a. Individual copies may be obtained by contacting ALC Operations at the above address or on the CG DEAL web-site at <https://cgportal2.uscg.mil/communities/CGDEAL/Pages/Home.aspx>.

b. You may also obtain the AWBS software through the AWBS website at <https://awbs.hill.af.mil/>. If you do not already have an account on the website, one shall be established to gain access and download the software.

APPENDIX A TERMINOLOGY AND DEFINITIONS

ACTUAL WEIGHT. The weight of a component, subassembly or the entire aircraft as determined by actually weighing at least one representative article. Frequently the actual weight for record keeping purposes is an average of several representative articles.

AFT CENTER OF GRAVITY LIMIT. The aft center of gravity limit is the most aft (rearward) permissible aircraft center of gravity location for a specific weight and configuration. Center of Gravity may be expressed in inches, %MAC or index.

AIR CARGO (CARGO). Stores, equipment or vehicles, which do not form part of the aircraft, and are either part or all of its payload.

AIRCRAFT MODIFICATION. Change in the physical characteristics of an aircraft accomplished either by a change in production specifications or by alteration of items already produced.

AIRCRAFT REFERENCE AXES. A set of three mutually perpendicular reference lines (longitudinal, lateral, and vertical) established to define the basic geometry of a major aircraft component, such as the wing, fuselage or nacelle. Each Model, Design, or Series aircraft have their unique reference axes which shall be provided to the customer or user of the aircraft. The fuselage reference system is normally used as the common set of axes in locating the aircraft center of gravity. The aircraft reference system shall be defined early in the aircraft development and is usually located in front of the aircraft and below the static ground level to eliminate the need for negative arms. However, the lateral reference axis is usually located down the centerline of the aircraft to make symmetrical calculations easier.

AIRCRAFT STORE. Any device intended for internal or external carriage and mounted on aircraft suspension and release equipment, whether or not the item is intended to be separated in flight from the aircraft. Aircraft stores are classified in two categories of expendable and non-expendable.

AIRCRAFT WEIGHING RECORD. An Aircraft Weighing Record, DD Form 365-2, is the form used to record data obtained from aircraft actual weighings and to derive the Basic Weight and Moment from the As- Weighed Weight and Moment.

AIR DROP LOAD. Reference 22 on the DD Form 365-4 Transport Form.

ALLOWABLE GROSS WEIGHTS. The allowable Gross Weight is the not to be exceeded weight of a loaded aircraft. The aircraft flight manuals specify allowable weights for particular configurations or conditions. Some examples are Allowable Takeoff Weight, Allowable Landing Weight, and Allowable Limiting Wing Fuel Weight.

ALLOWABLE LOAD. Maximum load as determined in the LIMITATIONS table. Reference 13 on the DD Form 365-4 Transport Form.

AMMUNITION. Projectiles, such as bullets and shot, together with their fuses and primers that can be fired from guns or otherwise propelled.

ARM. An arm is the distance of the center of gravity of an item from a reference datum. When computing arms: note that arms are not additive, and shall be calculated by dividing the moment (not simplified) by the weight.

AUTOMATED FORM F (AFF) GENERATOR. An AFF is an electronic Form F Generator that is used to determine the aircraft weight and center of gravity location for any flight or ground configuration and produce a Form F.

AUTOMATED WEIGHT AND BALANCE SYSTEM (AWBS). The Automated Weight and Balance System is a software application that enables computer-based management of aircraft records as a replacement for DD 365 series forms. Aircraft weight data and loading arrangements may be updated digitally which improves efficiency and reduces mathematical errors.

AVERAGE WEIGHT. The summation of individual weights divided by the number of the individual weights: $(\text{First Weight} + \text{Second Weight} + \text{Third Weight})/3 = \text{Average Weight}$.

BALANCE. Balance is a condition of stability, which exists in an aircraft when all weights and forces are acting in such a way as to prevent rotation.

BALANCE ARM. The balance arm is the arm at which a number of weights could be concentrated to produce the same effect as they produced when separated. The balance arm results from dividing the total moment by the total weight.

BALANCE COMPUTER. A balance computer is a calculating device, mechanical or electronic, which is used to determine the aircraft center of gravity location for any flight or ground configuration.

BALLAST. Ballast is weight specifically put in an aircraft to remain within permissible center of gravity limits.

BASIC ARM or BASIC CG. The basic arm or basic CG is the distance from the reference datum to the aircraft center of gravity consistent with the Basic Weight condition. Basic arm or basic CG is determined by dividing the aircraft basic moment by the aircraft Basic Weight.

BASIC INDEX. A basic index is a number, which represents a basic moment on an aircraft load adjuster.

BASIC MOMENT. The basic moment is the sum of the moments of all items included in the aircraft Basic Weight.

BASIC WEIGHT. Basic Weight is the total weight of the aircraft, installed systems, and items necessary for basic flight operation. Basic Weight is independent of mission and establishes the starting basis for all mission loading scenarios. Examples of items in Basic Weight may be guns, unusable fuel, oil, ballast, oxygen, and internal and external equipment not disposed of during flight. The current Basic Weight is the last entry on Chart C either in the Basic Weight column in AWBS or in the CURRENT TOTAL BASIC AIRCRAFT column using DD 365-3.

BASIC WEIGHT AND BALANCE RECORD. The Basic Weight and balance record is a continuous series of DD Forms 365-3, referred to as Chart C. It is a continuous and permanent record of aircraft weight, moment, and load adjuster index or center of gravity position.

BASIC WEIGHT CHECKLIST RECORD. The Basic Weight Checklist Record is a completed collection of DD Form 365-1, referred to as Chart A. It is a list of equipment by aircraft compartment that is, or can be, installed in the aircraft.

BUTTLINES. Buttlines are reference locations in the lateral (left or right) direction from the aircraft longitudinal (forward to aft) reference datum, which is usually the aircraft centerline.

CALCULATED WEIGHT. The weight of a component or subassembly, as determined by calculation using engineering data that has completed the design and approval cycle during the detail design phase.

CARGO. Reference 13 on the DD Form 365-4 Transport Form and Reference 3 on the DD Form 365-4 Tactical Form.

CAUTION RANGE. A caution range is a region of a weight and center of gravity diagram, or table, which indicates reduced aircraft capabilities, such as aircraft control or structural limitations.

CENTER OF GRAVITY (CG). The center of gravity, CG, is a point at which an item's weight is concentrated and about which the item would balance if suspended. Center of Gravity may be expressed in inches, %MAC or index.

CENTRAL SERVER. A web service designed to store electronic aircraft records when using AWBS. When correctly configured, and with proper permissions, users can export aircraft records to the Central Server and import aircraft records from the Central Server. The Central Server acts as a central repository or transfer hub for aircraft records.

CENTROID. Centroid is commonly used as the average arm or geometric center of a compartment.

CHART A. See BASIC WEIGHT CHECKLIST RECORD.

CHART C. See BASIC WEIGHT AND BALANCE RECORD.

CHART E. See LOADING DATA.

CHORD. A chord is an imaginary straight line joining the leading and trailing edges of an airfoil (such as a wing or tail surface).

COMPARTMENT. Reference 13 on the DD Form 365-4 Transport Form and Reference 3 on the DD Form 365-4 Tactical Form.

CONFIGURATION. Configuration is a particular arrangement and quantity of structure, systems, internal and external equipment, stores, fuel, and other items, and the positions of such things as wings, slats, flaps, and landing gear.

CORRECTIONS. Used to make load adjustments on the paper DD 365-4 forms. Corrections block of DD Form 365-4 Transport Form and DD Form 365-4 Tactical Form.

DANGER RANGE. A danger range is a region of a weight and center of gravity diagram, or table, within which flight and/or ground operation of an aircraft is not permitted.

DATUM. See REFERENCE DATUM.

DD FORM 365. See RECORD OF WEIGHT AND BALANCE PERSONNEL.

DD FORM 365-1. See BASIC WEIGHT CHECKLIST RECORD.

DD FORM 365-2. See AIRCRAFT WEIGHING RECORD.

DD FORM 365-3. See BASIC WEIGHT AND BALANCE RECORD.

DD FORM 365-4. See WEIGHT AND BALANCE CLEARANCE FORM.

DRAINABLE FUEL. Drainable fuel is that portion of unusable fuel that can be drained out of an aircraft through drain points after defueling in accordance with appropriate instructions.

EMERGENCY EQUIPMENT. Any emergency equipment not included in Basic Weight. Reference 6 on the DD Form 365-4 Transport Form.

ESTIMATED LANDING CG. Reference 25 on the DD Form 365-4 Transport Form and Reference 17 on the DD Form 365-4 Tactical Form.

ESTIMATED LANDING FUEL. Reference 23 on the DD Form 365-4 Transport Form and Reference 15 on the DD Form 365-4 Tactical Form.

ESTIMATED WEIGHT. Weight determined by any means other than by calculation or actual measurement.

EXPENDABLE. Includes items that will be or could be consumed or disposed of during flight such as usable fuel, paratroops, airdrop cargo, ammunition, missiles, rockets, bombs, flares or chaff.

EXPENDABLE STORE. An aircraft store such as weapons, external fuel tanks, pyrotechnic devices, sonobuoys, signal and underwater sound devices or other similar items that may be separated from the aircraft in flight under normal or emergency situations. These items are included in Worst Case calculations.

EXTRA EQUIPMENT. Any extra equipment not included in Basic Weight. Reference 7 on the DD Form 365-4 Transport Form.

FLIGHT GROSS WEIGHT. Flight Gross Weight is the weight of the aircraft, its contents, and external items during flight. It is also known as Flight Weight and In-Flight Weight.

FLOOR LOADING. Floor loading is the weight of a load divided by the area of the floor upon which the weight is placed. Specific Aircrew Flight Manual, Cargo Loading Manuals, and/or Charts E will usually specify floor loading limits and total load capacity for various compartments of the aircraft.

FORM B. See AIRCRAFT WEIGHING RECORD.

FORM F. See WEIGHT AND BALANCE CLEARANCE FORM.

FORWARD CENTER OF GRAVITY LIMIT. The forward center of gravity limit is the most forward permissible aircraft center of gravity location for a specific weight and configuration. Center of Gravity limits may be expressed in inches, %MAC or index.

FULCRUM. A fulcrum is a pivot or support about which items can be balanced or rotated.

FUSELAGE STATION (AIRCRAFT STATION). Fuselage stations are reference locations measured in the longitudinal direction (forward or aft) from a reference datum which is usually well forward of the aircraft. A station forward of the reference datum is negative (-) while a station aft of the reference datum is positive (+).

GROSS WEIGHT (GW). Gross Weight is the total weight of the aircraft at any time, including its contents and externally-mounted items. The Gross Weight is continually changing throughout flight and/or ground operations so, typically, a value is usually qualified for a particular phase of flight.

GROUP A (A-KIT). Group A items are provisions for avionics line replaceable units (LRUs or WRAs). Group A items include wires, wire bundles, cables, RF transmission lines, connecting devices, mounting hardware, cooling plumbing and ducting, and items required for the installation of antennas, LRUs, WRAs, control displays, etc.

GROUP B (B-KIT). Group B items are those "black boxes" such as antennas, LRUs, WRAs, control and displays that are easily replaceable items in the electronic system.

HOISTING WEIGHT. The Hoisting Weight is the highest weight required for hoisting at the designated hoisting points considering combinations of hoisting points. This weight is usually defined as the Maximum Ground Weight minus the crew and passengers, and is used to design the hoisting point loads and related structures. This is to allow for a timely removal of an aircraft disabled on a runway.

IN AIRCRAFT. Basic Weight items on the aircraft during aircraft inventory and noted on DD FORM 365-1 - BASIC WEIGHT CHECKLIST RECORD.

INDEX. See LOAD ADJUSTER INDEX.

JIG POINTS. A jig point is a hole, fitting, or other fixture, which is a known, constant distance from the reference datum for all aircraft of the same model designation.

LANDING GROSS WEIGHT. (Also known as Estimated Landing Gross Weight or Landing Weight.) Landing Gross Weight is the weight of the aircraft, its contents and external items when the aircraft lands. It is calculated as Takeoff Gross Weight minus load items expended in flight such as fuel, stores, ammunition, cargo and paratroops.

LATERAL AXIS. An axis from side to side of an aircraft (along the wing span).

LEADING EDGE OF THE MEAN AERODYNAMIC CHORD (LEMAC). The LEMAC is the distance from the longitudinal reference datum to the leading edge of the Mean Aerodynamic Chord (MAC).

LEVELING LUGS. Leveling lugs are fixtures attached to the aircraft to support a spirit level or inclinometer when leveling the aircraft.

LEVELING PLATE. A leveling plate is a target, with index markings, which is attached to the aircraft and is used with a plumb bob when leveling the aircraft.

LIMITING WING FUEL ALLOWABLE GROSS WEIGHT. Limiting Wing Fuel Allowable Gross Weight is the weight above which any additional load shall be fuel carried in the wing.

LOAD ADJUSTER. A load adjuster is a slide rule type mechanical balance computer.

LOAD ADJUSTER INDEX. A load adjuster index is a number that represents moment on the aircraft load adjuster and, in conjunction with aircraft weight or index formula, permits center of gravity calculations.

LOAD ITEM. Any item that has a size and weight value that is added to an airframe/platform and is not considered part of Basic Weight. Load items could be crew, crew baggage, fixed equipment, emergency equipment, internal cargo items, external cargo items, sling loads, external stores, expendable items, non-expendable items, jettisonable items, fuel or temporary ballast. These items are listed in the Chart E.

LOADING CONTROL. Loading Control, as used in weight and balance, is the use of weight and balance forms and loading data to ensure that the aircraft weight, center of gravity, and any other loading limits are not exceeded during flight or ground operations.

LOADING DATA (Chart E). Loading Data contains instructions for aircraft actual weighing, aircraft diagrams, loading limits, general instructions affecting aircraft loading, and the weight, arm and moment/index information necessary to perform loading control.

LOADING LIMITS. Loading Limits are restrictions, such as permissible center of gravity range, floor loading, compartment capacity, and Gross Weight, beyond which aircraft loading is not permitted.

LONGITUDINAL AXIS. The fore and aft axis. It is normally the fore and aft axis through the center of the aircraft.

LRU. Line Replaceable Unit (similar to WRA).

MANUFACTURING VARIATION. The difference between the Current Weight and the Actual Weight after the contractor has applied his best effort to account for the variation in tangible items (fuel cells, purchased parts, equipment items, configuration, etc.) to reconcile any initial or consistently repeated variation from the weight bookkeeping records.

MASS PROPERTIES. Mass properties is the term that refers to weight, center of gravity, and moment of inertia of an item.

MASTER CHART A. Chart A that standardizes the basic weight checklist for a specific MDS/TMS aircraft. May be in either a DD 365-1 or electronic format. Master Charts A may include illustrations/drawings/photos/part numbers to aid in the inventory process.

MAXIMUM CATAPULT WEIGHT LIMIT. The Maximum Catapult Weight is the Maximum Launch Weight for which shipboard launch is required within the structural limits of the airframe, wind over deck (WOD) capability, and launch end speed of the ship system.

MAXIMUM GROSS WEIGHT LIMIT. See Allowable Gross Weight.

MAXIMUM GROUND WEIGHT. The Maximum Ground Weight is the highest weight required for ramp, taxi- way, and runway usage. This weight is frequently referred to as Maximum Ramp Weight.

MAXIMUM IN-FLIGHT WEIGHT LIMIT. The Maximum Flight Weight is the highest weight required or allowed for flight. The normal definition of Maximum Flight Weight is the Operating Weight of the aircraft plus maximum internal and external payload and maximum internal and external fuel. Care should be taken when addressing aircraft with in-flight refueling capability. In these aircraft, the Maximum Flight Weight may exceed the Maximum Takeoff Weight.

MAXIMUM LANDING WEIGHT. The maximum Gross Weight due to design or operational limitations at which an aircraft is permitted to land.

MAXIMUM RAMP WEIGHT. The maximum Gross Weight for all ground operations.

MAXIMUM TAKE-OFF WEIGHT. The maximum Gross Weight due to design or operational limitations at which an aircraft is permitted to take off.

MAXIMUM ZERO FUEL WEIGHT (MZFW). Maximum Zero Fuel Weight is the maximum permissible weight of the loaded aircraft before any usable fuel is added.

MDS (MODEL/DESIGN/SERIES). MDS – Refers to model or Mission/Design/Series (i.e. F-16A, F-4E, C141B, UH-1N, etc.), which is synonymous with TMS (Type/Model/Series).

MEAN AERODYNAMIC CORD (MAC). The theoretical

average or mean chord of a lifting surface such as the wing of a fixed-wing aircraft. Typically, a wing chord is longer at the root near the body and it tapers to a shorter chord at the tip. The MAC is an overall average chord representative of an entire wing using in aerodynamic computations and analysis.

MISCELLANEOUS VARIABLES. As required by the Command. Reference 8 on the DD Form 365-4 Tactical Form.

MOMENT. Moment is a measure of a tendency to rotate an object due to a force applied at a particular point on the object. In aircraft weight and balance, the moment of an item is the weight (force) of the item multiplied by its balance arm.

NONEXPENDABLE STORE. A store such as a rack, launcher, pod, internal fuel tank, or other similar item that will not separate from the aircraft in flight under normal operations. These items are not included in Worst Case calculations.

OPERATING ITEMS. Operating items include crew, and aircraft / mission dependent items such as internal and external auxiliary fuel tanks, guns, weapon suspension and release equipment, cargo handling equipment, crew baggage, steward equipment, special mission fixed equipment and emergency items which are not included in Basic Weight.

OPERATING WEIGHT. Operating Weight is the sum of aircraft Basic Weight and operating items.

OPERATING WEIGHT EMPTY / OPERATING EMPTY WEIGHT. Operating Weight Empty and Operating Empty Weight are variously defined civil aviation terms which differ from and are not to be confused with the military term Operating Weight.

PASSENGER. A passenger is any occupant on the aircraft not performing a crew duty and not logging flying time.

PAYLOAD. Payload is any item that is being transported and is directly related to the mission or purpose of the flight as opposed to items that are necessary for the flight operation. Payload can include, but is not limited to, passengers, cargo, passenger baggage, ammo, internal and external stores, and fuel that are to be delivered to another aircraft or site. Payload may or may not be expended in flight. Payload is a type of Load Item.

PERCENT MAC (% MAC). Percent MAC expresses a location along the aircraft longitudinal axis as a percentage of the mean aerodynamic chord of the aircraft.

PERMANENT BALLAST. Permanent ballast is ballast which is required to be in the aircraft at all times and is a CHART A item.

PERMISSIBLE GROSS WEIGHT. See ALLOWABLE GROSS WEIGHT.

PERMISSIBLE LANDING CG. Forward and Aft CG limits from the allowable flight envelope for the estimated landing condition. Limitations block of DD Form 365-4 Transport Form and DD Form 365-4 Tactical Form.

PERMISSIBLE TAKEOFF CG. Forward and Aft CG limits from the allowable flight envelope for the estimated takeoff condition. Limitations block of DD Form 365-4 Transport Form and DD Form 365-4 Tactical Form.

PERMISSIBLE ZERO FUEL CG. Forward and Aft CG limits from the allowable flight envelope for the Estimated Zero Fuel condition. Limitations block of DD Form 365-4 Transport Form.

RAMP WEIGHT. Gross Weight of the aircraft prior to engine start and defined as Operating Weight plus usable fuel plus payload.

REACTION. See WEIGHING REACTION POINTS.

RECORD OF WEIGHT AND BALANCE PERSONNEL. The record of Weight and Balance Personnel, DD Form 365, is the form used to provide a permanent continuous record of weight and balance personnel responsible for maintaining the aircraft weight and balance handbook.

REFERENCE DATUM. A reference datum is an imaginary plane from which distances are measured for aircraft weight and balance purposes. The balance arm of a reference datum is by definition zero. Aircraft have three reference datum from which balance arms are measured, longitudinal (using fuselage station), lateral (using buttlines), and vertical (using waterlines) reference datum. The three reference datum are always perpendicular to each other. The longitudinal reference datum is usually forward of the nose, the lateral reference datum is usually parallel to the aircraft centerline, and the vertical datum is usually well below the aircraft. Balance arms are determined relative to the horizontal reference datum.

REPRESENTATIVE AIRCRAFT. A representative aircraft is one chosen as being typical of a number of aircraft of the same Model/Design with similar structure, systems, and equipment configurations.

SCALE CORRECTION FACTOR. A scale correction factor is used to modify weighing scale readings because of inherent inaccuracies of the scale. Such factors may be, but are not limited to: calibration correction factors with the use of mechanical scales, load cell correction factors when the load cell readings do not return to zero after unloading with the use of electronic scales, or gravitation correction factors which depend on the latitude where the scale/load cell is used. Refer to the scale's applicable manual for the appropriate factors.

SERIAL NUMBER. Bureau Number for USN/USMC.

SERVICE WEIGHT PICK-UP. Service weight pick-up is the known and unknown weight change due to items such as repairs, modifications, wear, dirt, moisture, and unaccountable weight.

SIMPLIFIED MOMENT. Simplified moment is a moment divided by an established constant such as 10, 100, 1000, 10,000, or 100,000. The value of the constant is identified in the Charts A and E for the aircraft.

STEWARD'S EQUIPMENT. Any steward's equipment not included in Basic Weight. Reference 5 on the DD Form 365-4 Transport Form.

TAKEOFF CG. Reference 17 on the DD Form 365-4 Transport Form and Reference 10 on the DD Form 365-4 Tactical Form.

TAKEOFF CONDITION. Reference 19 on the DD Form 365-4 Transport Form and Reference 12 on the DD Form 365-4 Tactical Form.

TAKEOFF GROSS WEIGHT (TOGW). The Gross Weight of the aircraft at the time the aircraft becomes airborne and defined as Ramp Weight minus taxi fuel.

TARE. Tare is the weight of equipment necessary for weighing the aircraft, such as chocks, blocks, slings, and jacks, which is included in the scale reading but is not part of the aircraft weight. It can also include a Scale Correction Factor.

TEMPORARY BALLAST. Temporary ballast is a Form F operating item used to replace missing items such as crew members, armament, and equipment, in order to maintain the aircraft center of gravity within limits and/or to simulate a specific loading condition.

TOTAL AIRCRAFT WEIGHT. The sum of Operating Weight, fuel, and water injection fluid (if applicable).

TOTAL PAYLOAD. Sum of all payload items.

TOTAL WEIGHT ADDED. Used to summarize load adjustments for the corrections block on the paper DD 365-4 forms. Corrections block of DD Form 365-4 Transport Form and DD Form 365-4 Tactical Form.

TOTAL WEIGHT REMOVED. Used to summarize load adjustments for the corrections block on the paper DD 365-4 forms. Corrections block of DD Form 365-4 Transport Form and DD Form 365-4 Tactical Form.

TRAPPED FUEL. Trapped fuel is the fuel that remains in an aircraft after utilizing applicable technical manuals to defuel the aircraft and drain individual tanks and lines.

TYPE/MODEL/SERIES (TMS). Designation of an aircraft design such as F/A-18E, MH-60S or MV-22B. TMS is synonymous with MDS (Mission/Design/Series).

UNACCOUNTABLE WEIGHT / MOMENT. Unaccountable weight/moment is any change in Basic Weight/Moment, which is not reflected by an entry in the Chart C.

UNUSABLE FUEL. Unusable fuel is the fuel remaining in the aircraft after engine fuel starvation when the aircraft is in a specified attitude.

USABLE FUEL. Fuel onboard at engine start and available for aircraft operations.

USEFUL LOAD. Useful load is the difference between Basic Weight and Gross Weight plus items necessary for basic flight operations such as unusable fuel, engine oil, oxygen and fixed armament. Useful Load includes fuel, oil, crew, passengers, cargo, and other items carried as necessary for mission execution.

WATERLINE. Waterline are locations in the vertical (up and down) direction measured from a reference datum which is usually well below the aircraft.

WATER INJECTION. For aircraft using water injection engines. Reference 11 on the DD Form 365-4 Transport Form.

WEIGHING REACTION POINTS. Weighing reaction points are those points upon which the aircraft weight is supported during weighing.

WEIGHT AND BALANCE AUTHORITY. Person who has the responsibility to ensure the weight and balance work is complete and correct.

WEIGHT AND BALANCE CUSTODIAN. Qualified person assigned to weight and balance work.

WEIGHT AND BALANCE CLEARANCE FORM. The Weight and Balance Clearance Form, DD Form 365-4, is referred to as Form F. Tactical and Transport Forms F record weight, moment or index, and center of gravity calculations to ensure the aircraft remains within its weight and balance limitations.

WEIGHT AND BALANCE HANDBOOK. An aircraft weight and balance handbook is a continuous and permanent record of weight and balance of a particular aircraft.

WEIGHT AND BALANCE TECHNICIAN. Qualified person assigned to weight and balance work.

WRA. Weapons Replaceable Assembly. Similar to LRU.

ZERO FUEL CENTER OF GRAVITY (ZFCG). Zero Fuel Center of Gravity is the CG of the loaded aircraft without any usable fuel.

ZERO FUEL WEIGHT (ZFW). Zero Fuel Weight is the weight of the loaded aircraft without any usable fuel. See also Maximum Zero Fuel Weight.

ZERO WING FUEL WEIGHT. The weight of the loaded aircraft without any usable fuel in the wings.

THIS PAGE LEFT INTENTIONALLY BLANK

**APPENDIX B
ACRONYMS**

ACMS Aviation Computerized Maintenance System	FRC Fleet Readiness Center
AETC Air Education and Training Command	FS Fuselage Station
AFF Automated Form F Generator	FWD Forward
AFI Air Force Instruction	GUMC Gear Up Moment Change
AFLCMC Air Force Life Cycle Management Center	GW Gross Weight
AFMC Air Force Materiel Command	JDRS Joint Discrepancy Reporting System
AFRIMS Air Force Records Information Management System	LEMAC Leading Edge of the Mean Aerodynamic Chord
ALC Air/Aviation Logistics Center	MAC Mean Aerodynamic Chord
AMMO Ammunition	MAJCOM Major Command
AR Army Regulation	MDS Model/Design/Series
AWBS Automated Weight and Balance System	MMCO Maintenance/Material Control Officer
BL Buttline	MOM Moment
BUNO Bureau Number	MWO Modification Work Order
CAAS Common Avionics Architecture System	NATOPS Naval Air Training and Operating Procedures Standardization
CAC Common Access Card	NATIP Naval Aviation Technical Information Product
CGTO Coast Guard Technical Order	NAVAIRSYSCOM Naval Air Systems Command
COMDTINST Commandant Instruction	NSWC Naval Surface Warfare Center
COR Contracting Officer's Representative	PDM Programmed Depot Maintenance
CG Center of Gravity	PG Process Guide
CNATT Center for Naval Aviation Technical Training	REF Reference
DA Department of the Army	SDLM Standard Depot Level Maintenance
DD/DOD Department of Defense	TB Technical Bulletin
EPM Enhanced Phase Maintenance	TCTO Time Compliance Technical Order
FMS Flight Management System	TD Technical Directive

TM Technical Manual

TMS Type/Model/Series

TO Technical Order

TPDR Technical Publication Discrepancy Report

UAS Unmanned Air System

UAV Unmanned Air Vehicle

WAM Weight x Arm = Moment

Wt Weight

%MAC Percent Mean Aerodynamic Chord

APPENDIX C
SCALE CORRECTIONS BLOCK TABLE FACTORS

Table C-1. Latitude and Altitude

Degree	0 ft.	1000 ft.	2000 ft.	3000 ft.	4000 ft.	5000 ft.	6000 ft.	7000 ft.
0	1.0027	1.0028	1.0029	1.0030	1.0031	1.0032	1.0033	1.0034
5	1.0026	1.0027	1.0028	1.0029	1.0030	1.0031	1.0032	1.0033
10	1.0025	1.0026	1.0027	1.0028	1.0029	1.0030	1.0031	1.0032
15	1.0023	1.0024	1.0025	1.0026	1.0027	1.0028	1.0029	1.0030
20	1.0021	1.0022	1.0023	1.0024	1.0025	1.0025	1.0026	1.0027
25	1.0017	1.0018	1.0019	1.0020	1.0021	1.0022	1.0023	1.0024
30	1.0014	1.0015	1.0016	1.0017	1.0017	1.0018	1.0019	1.0020
35	1.0009	1.0010	1.0011	1.0012	1.0013	1.0014	1.0015	1.0016
40	1.0005	1.0006	1.0007	1.0008	1.0009	1.0010	1.0011	1.0012
45	1.0000	1.0001	1.0002	1.0003	1.0004	1.0005	1.0006	1.0007
50	0.9996	0.9997	0.9998	0.9999	1.0000	1.0001	1.0002	1.0003
55	0.9991	0.9992	0.9993	0.9994	0.9995	0.9996	0.9997	0.9998
60	0.9987	0.9988	0.9989	0.9990	0.9991	0.9992	0.9993	0.9994
65	0.9983	0.9984	0.9985	0.9986	0.9987	0.9988	0.9989	0.9990
70	0.9980	0.9981	0.9982	0.9983	0.9984	0.9985	0.9986	0.9987
75	0.9978	0.9979	0.9979	0.9980	0.9981	0.9982	0.9983	0.9984
80	0.9976	0.9977	0.9978	0.9979	0.9979	0.9980	0.9981	0.9982
85	0.9974	0.9975	0.9976	0.9977	0.9978	0.9979	0.9980	0.9981
90	0.9974	0.9975	0.9976	0.9977	0.9978	0.9979	0.9980	0.9981

C.1 **EXAMPLE.** An aircraft is weighed in a hanger at 30 degrees latitude and an altitude of 2000 ft MSL.

C.1.1 Multiply each scale reading by the correction factor of 1.0016 and enter the result on the Form B for each reaction weight. (15,000 lbs x 1.0016 = 15,024 lbs).

NOTE

Scales are calibrated to 45 degrees latitude and 0 feet altitude.

All scales should be adjusted to current location of aircraft weighing.

THIS PAGE LEFT INTENTIONALLY BLANK